

CBS-1251; CBS-1252 and CBS-1253 Extractor Plus Brewing System FETCO PLUS® Commercial Beverage Equipment



CBS-1251 & CBS-1252 1½ gallon brewer with FETCO 1½ Gallon L4D dispensers (sold separately) CBS-2153 2 gallon Extractor Plus Brewers



CONTACT INFORMATION

FETCO® FOOD EQUIPMENT TECHNOLOGIES COMPANY
600 ROSE ROAD
LAKE ZURICH • IL • 60047-0429 • USA
ON THE WEB: fetco.coffee
©2020-2021 FETCO
PATENTS: <https://www.fetco.com/pl/pages/patents,74.html>



fetco.com

PHONE: (800) 338-2699 (US & CANADA)
(847) 719-3000 (All Countries)
FAX: (847) 719-3001
EMAIL: sales@fetco.com
orders@fetco.com (to order parts and equipment)
techsupport@fetco.com (all service queries)

P213 REV. 000 November 2021

Coffee Brewer: CBS-1250 series

TABLE OF CONTENTS

Specifications and Requirements	2	F Error Codes	11
Electrical Configurations	3	G Counters	12
Enter Programming	5	H Save & Exit	13
Programing Menu Layout	5	Operator Training	14
Starting The Brew	6	Parts Diagram CBS-1251	18
A Program	7	Parts Diagrams CBS-1252 and CBS-1253	20
B General	8	CBS-1251 Tank Assembly	22
C Service Inputs	9	CBS-1252 and CBS1253 Tank Assembly	24
D Service Outputs	9	Quick connect spray head assembly	26
E Calibration	10	Wiring Diagrams	27
F Service Menu	10		

Specifications and Requirements

Water Requirements:

CBS-1251; CBS1252 & 1253:
20-75 psig, (138-517kPa) 1½gpm/(5.7lpm)

Water inlet fitting is a 3/8 inch male flare.
Brewer supplied with inlet valve adaptor for BSP to SAE

CBS-2151 and CBS-2152

Brew Volume: First Batch 1½ gallons/ 6 liters

Second Batch 1 gallon/ 3.8 liters

CBS-2153 -2 gallon

Brew Volume: First Batch 2 gallons/ 7.6 liters

Second Batch 1 gallon/ 3.8 liters

Total Brew Cycle—Factory Default Settings

CBS-2151 1½ gal Factory default setting

First batch 1½ gal: 6:30 minutes=[5 minute brew time + 1.30 minute drip delay] + 10% Bypass

Second batch-1 gallon: 5:30 minutes=[4 minute brew time + 1.30 minute drip delay] + 0% Bypass

CBS-2152 1½ gal Factory default setting:

First batch 1½ gal: 6:30 minutes=[5 minute brew time + 1.30 minute drip delay] + 15% Bypass

Second batch-1 gallon: 5:30 minutes=[4 minute brew time + 1.30 minute drip delay] + 0% Bypass

CBS-2153-2 gallon Factory default setting:

First batch 2 gal: 6:30 minutes=[5 minute brew time + 1.30 minute drip delay] + 15% Bypass

Second batch-1 gallon: 5:30 minutes=[4 minute brew time + 1.30 minute drip delay] + 0% Bypass

Brew-Process parameters are user controllable for:

Brew Volume, Brew Time, Prewet Percent, Bypass, Prewet Delay, and Drip Delay

Electrical:

See electrical configuration chart on page three.
CBS-1250 series brewers use a terminal block for electrical connection

Tank Temperature, as set by factory:

200°F (93°C) inside water tank (at sea level)

Water supply: (Optimal) 100-150TDS

All beverage equipment must use filtered water.

Weights and Capacities

Model	Height	Width	Depth	Water tank capacity	Empty Weight	Filled Weight	Shipping Weight	Shipping Dimensions
CBS-1251 1½ gal	36 7/8 in 940 mm	12 3/4 in 320 mm	22 1/2 in 570 mm	6.5 gallon 24.4 L	53 lbs 24 kg	107 lbs 48.3kg	63 lbs 28.6 kg	38" x 18" x 24" 96.5 x 45.7 x 61 cm
CBS-1252 1½ gal	36 7/8 in 940 mm	21 7/8 in 550 mm	22 1/2 in 570 mm	11.1 gallon 42.1 L	77 lbs 35.0 kg	174 lbs 78.9 kg	97 lbs 44 kg	38" x 24" x 27" 96.5 x 61 x 68.6 cm
CBS-1253 2 gal	39 in 99.1 mm	21 7/8 in 550 mm	22 1/2 in 570 mm	11.1 gallon 42.1 L	82 lbs 37.2 kg	180 lbs 81.6 kg	97 lbs 44 kg	40" x 24" x 27" 102 x 61 x 68.6 cm
CBS-1251 & CBS-1252 Calibrated for 1½ gallons/ 6 liters		CBS-1253 Calibrated for 2 gallons/ 8 liters		Filter Paper all models 15" X 5 ½"—standard Or use FETCO # F001		Brewers ship with plastic brew baskets. See page 25 for optional brew baskets		

Rough-In Drawings

1201.00053.00 (CBS-1251) 1201.00052.00 (CBS-2152)

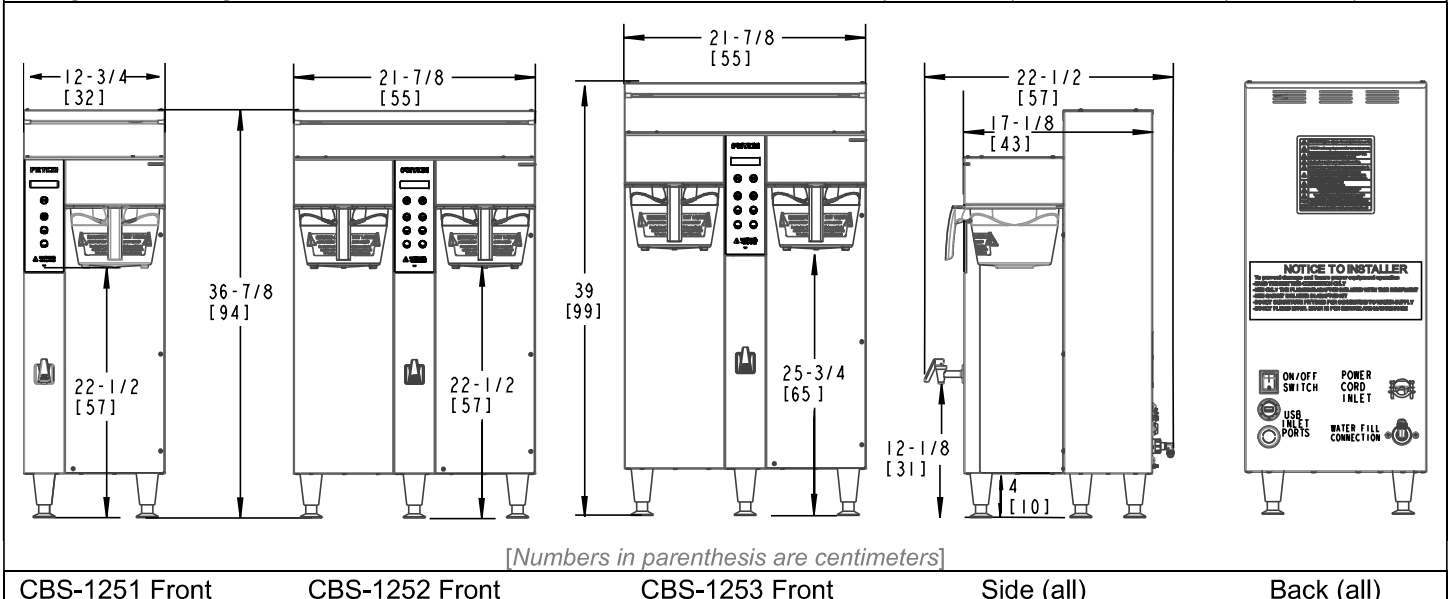

Electrical Configurations

CBS-1251PLUS Single 1½ Gallon-6 Liter Coffee Brewers Domestic and International models Electrical and Output Specifications All brewers have terminal block electrical utility connection 50Hz or 60Hz							
Configuration Codes	Heater Configuration	Voltage	Phase	Wires	KW	Amp Draw	Brew-Volume/Hour
E1251US-1B230-PM110	2 X 3.0 kW	208-240	1	2+G	4.5-6.0	22.2-25.5	15.0 gal/57 liters
E1251US-1B230-MM110	2 X 3.0 kW	208-240	1	2+G	4.5-6.0	22.2-25.5	15.0 gal/57 liters
E1251IN-1B140-PM110	1 X 4.0 kW	200-240	1	2+G	2.8-4.0	14.4-17.2	10.6 gal/40.3 liters
E1251IN-1B150-PM110	1 X 5.0 kW	200-240	1	2+G	3.5-5.0	17.9-21.3	13.3 gal/50.4liters
E1251IN-1B230-PM110	2 X 3.0 kW	200-240	1	2+G	4.2-6.0	21.3-25.5	15.0 gal/57 liters

CBS-1251PLUS Single 1½ Gallon-6 Liter Coffee Brewers International models Electrical and Output Specifications All brewers have terminal block electrical utility connection 50Hz or 60Hz							
Configuration Codes	Heater Configuration	Voltage	Phase	Wires	KW	Amp Draw	Brew-Volume/Hour
E1251NM-1B230-PM110	2 X 3.0 kW	208-240	1	2+G	4.2-6.0	21.3-25.5	15.0 gal/57 liters

CBS-1252PLUS Twin 1½ Gallon-6 Liter Coffee Brewers Field configurable Domestic Electrical and Output Specifications All brewers have terminal block electrical utility connection 50Hz or 60Hz							
Configuration Codes	Heater Configuration	Voltage	Phase	Wires	KW	Amp Draw	Brew-Volume/Hour
E1252US-UB230-PM110 Selectable (1 or 3 phase) Sold as 3 phase	2 X 3.0 kW	208-240	1	2+G	4.5-6.0	22.2-25.5	15.9 gal/60.4 liters
	3 X 3.0 kW	208-240	3	3+G	6.8-9.0	19.3-22.2	23.9 gal/90.6 liters
E1252US-UB250-PM110 Selectable (1 or 3 phase) Sold as 3 phase	2 X 5.0 kW	208-240	1	2+G	7.6-10.0	36.6-42.2	25.3 gal/97 liters
	3 X 5.0 kW	208-240	3	3+G	11.3-15.0	31.8-36.6	30.0 gal/114 liters

CBS-1252PLUS Twin 1½ Gallon-6 Liter Coffee Brewers Domestic and International models Electrical and Output Specifications All brewers have terminal block electrical utility connection 50Hz or 60Hz							
Configuration Codes	Heater Configuration	Voltage	Phase	Wires	KW	Amp Draw	Brew-Volume/Hour
E1252IN-1B230-PM110	2 X 3.0 kW	200-240	1	2+G	4.2-6.0	21.3-25.5	15.9 gal/60.4 liters
E1252IN-1B250-PM110	2 X 5.0 kW	200-240	1	2+G	7.0-10.0	35.2-42.2	26.6gal/100.7liters

CBS-1252PLUS Twin 1½ Gallon-6 Liter Coffee Brewers International models Electrical and Output Specifications All brewers have terminal block electrical utility connection 50Hz or 60Hz							
Configuration Codes	Heater Configuration	Voltage	Phase	Wires	KW	Amp Draw	Brew-Volume/Hour
E1252IN-3B330-PM110	3 X 3.0 kW	220/380 240/415	3	4+G	7.6-9.0	12.0-12.9	23.9 gal/90.6 liters
E1252IN-3B340-PM110	3 X 4.0 kW	220/380 240/415	3	4+G	10.1-12.0	15.8-17.2	30.0 gal/114 liters
E1252IN-3B350-PM110	3 X 5.0 kW	220/380 240/415	3	4+G	12.6-15.0	19.6-21.3	30.0 gal/114 liters

CBS-1252PLUS Twin 1½ Gallon-6 Liter Coffee Brewers Field configurable International Electrical and Output Specifications All brewers have terminal block electrical utility connection 50Hz or 60Hz							
Configuration Codes	Heater Configuration	Voltage	Phase	Wires	KW	Amp Draw	Brew-Volume/Hour
E1252NM-UB250-PM110 Selectable (1 or 3 phase) Sold as 3 phase	2 X 5.0 kW	208-240	1	2+G	7.6-10.0	36.6-42.2	26.6 gal/101 liters
	3 X 5.0 kW	208-240	3	3+G	11.3-15.0	31.8-36.6	30.0 gal/114 liters

CBS-1253PLUS Twin 2 Gallon-8 Liter Coffee Brewers continued on following page

CBS-1253PLUS Twin 2 Gallon-8 Liter Coffee Brewers Field configurable Domestic							
Electrical and Output Specifications All brewers have terminal block electrical utility connection 50Hz or 60Hz							
Configuration Codes	Heater Configuration	Voltage	Phase	Wires	KW	Amp Draw	Brew-Volume/Hour
E1253US-UB230-PM110 Selectable (1 or 3 phase) Sold as 3 phase	2 X 3.0 kW	208-240	1	2+G	4.5-6.0	22.2-25.5	15.9 gal/60.4liters
	3 X 3.0 kW	208-240	3	3+G	6.8-9.0	19.3-22.2	23.9 gal/90.6liters
E1253US-UB250-PM110 Selectable (1 or 3 phase) Sold as 3 phase	2 X 5.0 kW	208-240	1	2+G	7.6-10.0	36.6-42.2	25.3 gal/97 liters
	3 X 5.0 kW	208-240	3	3+G	11.3-15.0	31.8-36.6	30.0 gal/114 liters

CBS-1253PLUS Twin 2 Gallon-8 Liter Coffee Brewers Domestic and International models							
Electrical and Output Specifications All brewers have terminal block electrical utility connection 50Hz or 60Hz							
configuration Codes	Heater Configuration	Voltage	Phase	Wires	KW	Amp Draw	Brew-Volume/Hour
E1253US-1B230-PM110	2 X 3.0 kW	200-240	1	2+G	4.2-6.0	21.3-25.5	15.9 gal/60.4 liters
E1253US-1B250-PM110	2 X 5.0 kW	200-240	1	2+G	7.0-10.0	35.2-42.2	26.6gal/100.7liters
E1253IN-1B230-PM110	2 X 3.0 kW	200-240	1	2+G	4.2-6.0	21.3-25.5	15.9 gal/60.4 liters
E1253IN-1B250-PM110	2 X 5.0 kW	200-240	1	2+G	7.0-10.0	35.2-42.2	26.6gal/100.7liters

CBS-1253PLUS Twin 2 Gallon-8 Liter Coffee Brewers International models							
Electrical and Output Specifications All brewers have terminal block electrical utility connection 50Hz or 60Hz							
Configuration Codes	Heater Configuration	Voltage	Phase	Wires	KW	Amp Draw	Brew-Volume/Hour
E1253IN-3B330-PM110	3 X 3.0 kW	220/380 240/415	3	4+G	7.6-9.0	12.0-12.9	23.9 gal/90.6 liters
E1253IN-3B340-PM110	3 X 4.0 kW	220/380 240/415	3	4+G	10.1-12.0	15.8-17.2	30.0 gal/114 liters
E1253IN-3B350-PM110	3 X 5.0 kW	220/380 240/415	3	4+G	12.6-15.0	19.6-21.3	30.0 gal/114 liters
E1253NM-1B250-PM110	2 X 5.0 kW	200-240	1	2+G	7.0-10.0	35.2-42.2	26.6gal/100.7liters

CBS-1253PLUS Twin 2 Gallon-8 Liter Coffee Brewers Field configurable International							
Electrical and Output Specifications All brewers have terminal block electrical utility connection 50Hz or 60Hz							
Configuration Codes	Heater Configuration	Voltage	Phase	Wires	KW	Amp Draw	Brew-Volume/Hour
E1253NM-UB250-PM110 Selectable (1 or 3 phase) Sold as 3 phase	2 X 5.0 kW	208-240	1	2+G	7.6-10.0	36.6-42.2	25.3 gal/97 liters
	3 X 5.0 kW	208-240	3	3+G	11.3-15.0	31.8-36.6	30.0 gal/114 liters

EXAMPLE: SKU E1253US-UB230-PM110																
SKU NUMBER IDENTIFICATION KEY																
Product Line	Level		Family		Region ID		Phase	Voltage Range	# Heaters	Individual Heater Wattage		Brew Basket	Hot Water Faucet	Bypass	Brew Basket Locks	Power Cord
E	1	2	5	3	U	S	U	B	2	5	0	P	M	01	1	0
E=extractor					US =United States		1	A = 100-120	1	1.5		P=plastic	M=manual	1=Yes	1=Yes	0=Terminal Block
	12=PLUS Series		51= single side		IN = International		2	B = 200-240	2	1.7		M=metal	A=automatic	0=no	0=no	1= NEMA 5-15P
			52= dual side		CE = CE		3	C = 380-415	3	2.3			N=None			2=NEMA 5-20P
					NM = NOM	U = 1 or 3		D = 440-480		3.0						3=NEMA 6-15P
										4.0						4=NEMA 6-30P
			53= dual side 2 gallon					X=120 or 240 Dual Voltage		5.0						5= CEE 7/7 Schuko
																6=UK1-13P
																7= AUSTRALIAN

Enter Programming

Screens shown are for twin brewer. Single brewer will not have menu A4-A6.
There are seven menu groups-A-G . See the following pages for the batch parameter definitions and all settings for the brewer

TO ENTER PROGRAMMING

- 1-Turn brewer "OFF" from power switch
- 2-Turn power switch to "ON"
- ...Screen will initialize and then display digital process notifications
- 3-After Initialization-Red "STOP" Lamp turns on
- 4-Quickly press "STOP" button.

When brewer is In PROGRAMMING MODE
-the screen will display:

BATCH PRG
A (or B-H)

-Illuminated LED indicates active keypad positions

See the following pages for batch parameter definitions and all settings for the brewer

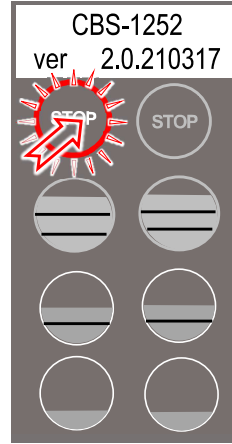
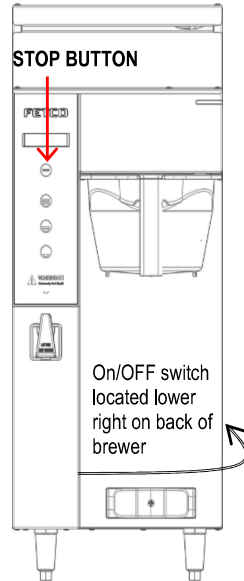

Turn power OFF
Turn power ON
Wait for red LED
And quickly press STOP button on front touch pane

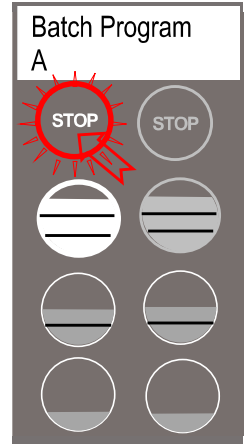

First screen will display for PROGRAMMING-A
Scroll through main menu topics by pressing "STOP" button.

Note: Only the left side buttons of a two sided brewer are used for programming

Programing Menu Layout

A10 to A70		B10-B40		C10-C50		D10-D90		E10-E70		F10-F120		G1-G15		H10-H11	
Batch Parameters		General Settings		Service Inputs		Service Outputs		Calibration		Service Menu		Counters		Exit and Save	
A11	Brew Volume	B1	Tank Temperature	C1	LLC Probe	D1	Heater SSR	E1	Ready Temp. Offset	F1	Firmware Ver.	G1	Filter Used	H1	Save Changes
A12	Brew Time	B2	Brew at Temp	C2	Basket Sensor	D2	Fill Valve	E2	LLC Sensitivity	F2	Bootloader Ver.	G2	Filter Life	H2	EXIT?
A13	Prewet Percent	B4	Show Tank Temp	C4	Tank Temperature	D3	Lt Brew Valve	E3	Slow Flow Compensate	F3	Select Model	G3	Filter Reset		
A14	Prewet Delay	B5	Units of Temp	C5	USB Drive	D4	Rt Brew Valve	E4	Lt Brew Flow	F4	Option Bypass	G4	Counter Reset		
A15	Bypass Percent	B6	Units of Volume	C6	Keyboard Test	D5	Lt Bypass Valve	E5	Rt Brew Flow	F5	Option BB Lock	G5	Choose Counter		
A16	Drip Delay	B7	Customer Name			D6	Rt Bypass Valve	E6	Lt Bypass Flow	F8	Backup to USB	G10	Brewer Volume [T]		
A20	Batch (2) Enabled	B8	Customers Name			D7	Lt Basket Lock	E7	Rt Bypass Flow	F9	Restore from USB	G11	Brewer Volume		
A21	Brew Volume	B9	Demo Mode			D8	Rt BasketLock			F10	Restore Defaults	G12	LT Brews[T]		
A22	Brew Time	B10	Eco Mode			D12	LCD Brightness %			F11	Error Log	G13	LT Brews		
A23	Prewet Percent	B11	Eco Idle Time			D13	LED Brightness %			F12	Erase Error Log	G14	Rt Brews [T]		
A24	Prewet Delay	B12	Eco Idle Temp							F13	Service Phone#	G15	Rt Brews		
A25	Bypass Percent	B13	Water Filter							F14	Override Lt BBS		See page 12		
A26	Drip Delay									F15	Override Rt BBS				
A30	Batch (3) Enabled									F16	Override Lt BBL				
A90	Copy Batch									F17	Override Rt BBL				
A91	Copy Batch: From														
A92	PASTE: To														

Top and middle batches are permanent SEE BOX on the following page for all "A" menus

Starting The Brew

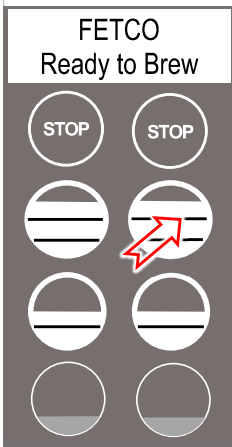

1. Turn the power switch "ON". (Twin Shown)
2. Prepare a brew basket with the correct size filter and appropriate amount of coffee.
3. Slide the brew basket completely into the rails.
4. Place a clean, empty, and preheated dispenser under the brew basket.
5. Select a batch & hold the corresponding BREW button in for 1 second to start
6. -STOP button will illuminate,
-Countdown time will display,
-Selected BREW button will flash to indicate brew is in progress.
-All other BREW buttons for that brew head will extinguish.
7. When the brew cycle is finished,
STOP button will extinguish and the BREW button will continue to flash for the amount of time programmed into the DRIP DELAY setting.
This indicates that coffee may still be dripping from the brew basket
For safety- do not remove brew basket until drip-out is complete.

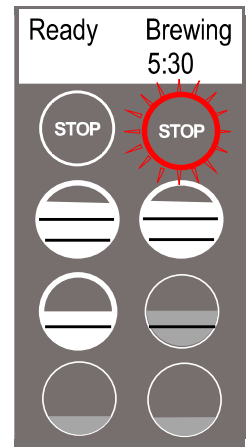

Twin Brewer ready to brew. Example shown: Pressing top right brew position

Brewing-see #6 above

RECIPE Location map

Viewing and changing settings for the brew recipes is from the "A" screens with the controls in PROGRAMMING.

The uppermost button positions are permanent and will not display programming step A_0. The table above shows in position A20 that a button position can be made **active or inactive**. Position A1 does not display this step

Single Side Models CBS-1231 Plus	←DISPLAY→	Dual Side Models CBS-1232 Plus	←DISPLAY
STOP		STOP STOP	
[Brew Button]	←STOP→	[Brew Button] [Brew Button]	←STOP
[Brew Button]	←BATCH A1→ <small>(permanent)</small>	[Brew Button] [Brew Button]	←BATCH A4 <small>(permanent)</small>
[Brew Button]	←BATCH A2→ <small>(enabled by factory)</small>	[Brew Button] [Brew Button]	←BATCH A5 <small>(enabled by factory)</small>
[Brew Button]	←BATCH A3→ <small>(disabled by factory)</small>	[Brew Button] [Brew Button]	←BATCH A6 <small>(disabled by factory)</small>

The "A" menu is the most accessed menu. It is for programming the batch volumes, brewing parameters, enabling or disabling brew buttons. The "A" menu moves through the six positions(CBS-1252-) or three positions(CBS-1251+) by entering the menu and pressing the left stop button. (only the left side is active for programming the CBS-1252+)

The A menus [A1-3 or A1-6] correspond to batch buttons [3 or 6] on the touch panel

Access the A menus to PROGRAM & make changes to individual menu recipes. Menu settings can be copied
Menu positions A1 and A4 [top position] are permanent. Menus A2, A3, A5, A6 can be removed by operator if desired

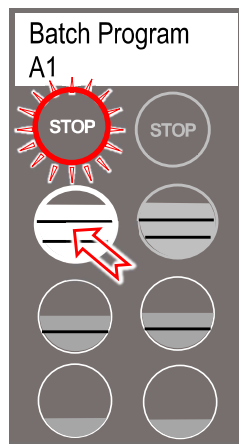

From A PRG screen
Press button 1 to go into to the A menu access screens. Continue pressing button #1 to enter programming for A1

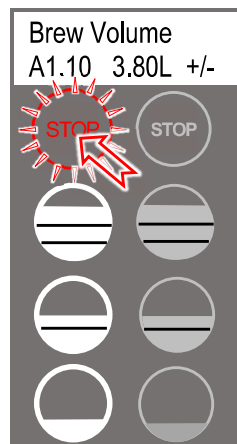

From A11 screen
Press **STOP** to scroll to A20. (A1&A4 are permanent)

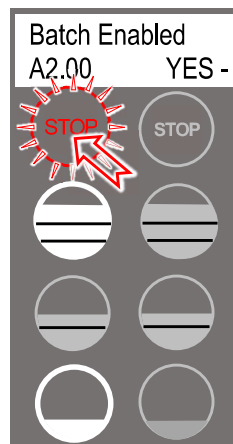

From A20 screen
Press STOP to scroll through the remaining (3 or 6) "A" menus. Make any changes as required

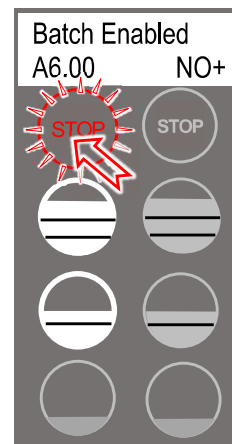

From A60 screen
Scroll out to remaining A10-to A70 programming keys. See SAVE & EXIT in previous table

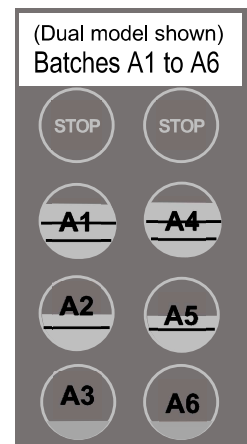

For single and twin
Position of batch buttons for CBS-1252+

The CBS-1251+ single position brewer has one row of buttons

A Program		Menu Features: Batch Parameters			
The settings below are shown for the top batch on a single brewer top left button on a twin brewer. See how to access all A menus on the previous page. Below are the brew settings for default A1 & A2 batches					
POSITION	Program Items	Factory set Default	Programming Range	Increments	Notes
A1.10	Batch Volume	1.5 gal 6.8 liters	0.51 to 2.00 gal 1.93 to 7.57L	0.01G 0.05L	
A1.10	Batch Volume CBS-2153 only	2 gallons 9.1 liters	0.51 to 2.66 gal 1.93 to 10.1L	0.01G 0.05L	
A1.20	Brew Time	5:00 minutes	2:00 – 12:00	0.30	Default total brew time is 6:30 minutes
A1.30	Prewet Perc.	0%	0.00 – 25.0%	1%	Percentage of total brew volume
A1.40	Prewet Delay (Pause after prewet completes)	0% [1:00 Min]	[0:10 – 5:00]	1:00 min	The time between prewetting and start of brew cycle. This feature appears ONLY if Prewet >0:00
A1.50	Bypass Percent	CBS-1251:10% CBS-1252/3:15%	0% – 40%	1%	Diverts brewing water from brew process
A1.60 This is a Safety Feature	Drip Delay	1:30 mm:ss	0:30 – 6:00 Min.		Time that brew basket remains locked during final drip-out →Drip delay remains “ON” for 1:30 minutes if STOP is pressed during brew†
A2.00	BATCH ENABLED	YES (Active)	Middle and Bottom batches A2,3,5,6	Batch on or off	Batches may be individually enabled, rewritten or deactivated
A2.10	Batch Volume	1.5 gal 6.8 liters	0.51 to 2.00 gal 1.93 to 7.57L	0.01G 0.05L	
A2.10	Batch Volume CBS-2153 only	2 gallons 9.1 liters	0.51 to 2.66 gal 1.93 to 10.1L	0.01G 0.05L	
A2.20	Brew Time	4.00 minutes	2:00 – 12:00	0.30	Default total brew time is 5:30 minutes
A2.30	Prewet Perc.	0%	0.00 – 25.0%	1%	Percentage of total brew volume
A2.40	Prewet Delay (Brew pause after prewet completes)	0% [1:00 Min]	[0:10 – 5:00]	1:00 min	The time between prewetting and start of brew cycle. This feature appears ONLY if Prewet >0:00
A2.50	Bypass Percent	CBS-1251:0% CBS-1252&3: 0%	0% – 40%	1%	Diverts brewing water from brew process
A2.60 This is a Safety Feature	Drip Delay	1:30 mm:ss	0:30 – 6:00 Min.		Time that brew basket remains locked during final drip-out →Drip delay remains “ON” for 1:30 minutes if STOP is pressed during brew†
A30	Batch Enabled A30 YES - NO +	NO-inactive (defaults to recipe A20 if activated)	Middle and Bottom batches A2,A3	Batch on or off	Batches may be individually enabled, rewritten or deactivated
A90 Batch Copy	Copy From Batch	A90	A90 1 (1-6)		
A91	Copy To Batch?	A91	A91.1 (1-6)		

PULSE BREW note. FETCO CBS-1200V+ brewers are factory programmed to pulse 2 cycles per minute brew time
Changing the brew time only will increase the pulses but will not change the volume of brew water delivered

B General Brewer Operation Control Settings, Adjust Brew Flow Rate					
POSITION	Program Items	Factory set Default	Programming Range	Increments	Notes
B1	Tank Temp.	200°F-or-93° C NOTE: Equipment is Fahrenheit by default	77° to 97°C 170°F to 207°F	0.5°C 1.0°F	Chart to correct for high altitude below
B2	Brew at Temp.	“YES”	ON/OFF	YES/NO	SEE NOTE BELOW
B4	Show Tank Temperature	YES	YES/NO		To display HW tank temperature on screen
B5	Units of Measure TEMPERATURE	F°-Fahrenheit	Fahrenheit/Celsius	C/F	NOTE: Overwrites user settings (see page 9)
B6	Units of Measure VOLUME	G-Gallons	Gallons/Liters/Ounces	Gal/L/Oz	NOTE: Overwrites user settings (see page 9)
B7	Customer Name	Off	NO or YES		For name on screen
B8	Customer Name	(only if above is “ON)	Scroll with batch keys	A-Z;a-z;0-9	16 characters total
B9	Demo Mode	DEMO ON/OFF			Demonstrates the controls for training. Disables all components in demo mode
B10	Eco Mode	On	ON/OFF	YES/NO	If Selected: Lowers hot water tank temperature after preset time of inactivity
B11	Eco Idle Time	1Hr	1-6 hours	1 hour	Time of inactivity to go into ECO Mode
B12	Eco Idle Temp	170°F	158-176°F	1 degree	Temperature that hot water tank is lowered to
B13	Water Filter	OFF	ON/OFF	YES/NO	Water filter life is accessed in G-Counters. This is user set and will display indicator to change water filter

BREW AT TEMPERATURE DEFINITIONS

DEFAULT: BREW AT TEMP: “ON”	
<p>(FACTORY DEFAULT FOR BREWER)</p> <p>“BREW at TEMP:</p> <p>-Batch will not start if tank temperature is below set point.</p> <p>-Display will show “HEATING” and hot water tank temperature</p> <p>The “BREW START” entry buttons will not illuminate until the hot water tank reaches the selected temperature.</p> <p>Controls allow both sides of dual brewer to operate if one side has an ongoing brew started and the second side brew is selected.</p> <p>Notifications shown on screen:</p> <p>TEXT: HEATING→Tank above 87°C/189°F-will allow brew at low temperature.</p> <p>Coffee flavor may be affected</p> <p>TEXT: L. HEAT→Tank above 77°C/170°F-will allow brew at low temperature.</p> <p>Coffee flavor will be noticeably affected</p>	<p>Hot water tank not at brew temp setpoint.</p> <p>Tank temp→</p> <p>STOP is not lit →</p> <p>BREW START buttons not lit, and are disabled.</p> <p>When hot water tank temperature is at setpoint. Buttons will illuminate and “READY” will be displayed</p>
<p>USER SELECTABLE OPTION: BREW AT TEMP: OFF (Not recommended) Unit will operate at lower temperature</p> <p>Allows brewing at any temperature above 77°C/170°F</p> <p>Below 70°C/170°F The brewer will display “HEATING”</p>	

Chart to correct for altitude for boiling point in tank water temperature.					
[ft]	[m]	Suggested Setting[°F]	Boiling point[°F]	Suggested Setting[°C]	Boiling point [°C]
0	0	205	212.0	96	100.0
500	152	205	211.0	96	99.5
1000	305	200	210.1	93	98.9
2000	610	200	208.1	93	97.8
2500	762	200	207.2	93	97.3
3000	914	200	206.2	93	96.8
3500	1067	197	205.3	92	96.3
4000	1219	195	204.3	91	95.7
4500	1372	194	203.4	90	95.2
5000	1524	194	202.4	90	94.7
5500	1676	193	201.5	89	94.2
6000	1829	192	200.6	89	93.6
6500	1981	191	199.6	88	93.1
7000	2134	190	198.7	87	92.6
7500	2286	188	197.8	86	92.1
8000	2438	187	196.9	86	91.6
8500	2591	185	196.0	85	91.1

C Service Inputs		Brewer Sensors and Keypad			
POSITION	Program Items	Factory set Default	Programming Range	Increments	Notes
C1	LLC Probe continuity	Direct read	Tank water resistance in TDS	≈850- LOW ≈1600-HIGH	Nominal values
C2	Brew Basket Sensor	L-YES R-YES	YES or NO		
C4	Tank Temperature	Direct read	Hot water tank temperature		Actual values
C5	USB Drive	NO	(not in use)		
C6	Keyboard Test	Calibrate	Checks buttons under membrane cover	YES/NO	Follow directions on the touch screen

D Service Outputs		Test Valves and Heaters; Set screen brightness			
POSITION	Program Items	Factory set Default	Programming Range	Increments	Notes
D1	Heater SSR Test	Press button 2 to test (button 1 stops test)	Activates heater Default is 10 sec..	Toggle +/- OFF or ON	Energizes Heater(s) WARNING! Service use only.
D2	Fill Valve Test	Press button 2 to test (button 1 stops test)	Activates valve Default is 10 sec.	Toggle +/- OFF or ON	Press To Test
D3	LT (left) Brew Valve Test	(Press to test)	Activates valve Default is 10 sec.	Toggle +/- OFF or ON	Runs valve to verify flow. NOTE: Have container under brew basket.
D4	RT (right) Brew Valve Test	(Press to test)	Activates valve Default is 10 sec.	Toggle +/- OFF or ON	Runs valve to verify flow. NOTE: Have container under brew basket.
D5	LT (left) Bypass Valve Test	(Press to test)	Activates valve Default is 10 sec.	Toggle +/- OFF or ON	Runs valve to verify flow. NOTE: Have container under brew basket.
D6	RT (right) Brew Valve Test	(Press to test)	Activates valve Default is 10 sec.	Toggle +/- OFF or ON	Runs valve to verify flow. NOTE: Have container under brew basket.
D7	LT (left) Brew Basket Lock Test	(Press to test)	Activates Brew Basket Lock	Toggle +/- OFF or ON	Press To Test
D8	RT (right) Brew Basket Lock Test	(Press to test)	Activates Brew Basket Lock	Toggle +/- OFF or ON	Press To Test
Single series displays right side only Left Valve display is only for twin side brewer.					
D12	LCD Brightness	Brightness=90%	20-100%	5%	Adjust LCD screen brightness only-Not for LEDs under buttons
D13	LED Brightness	Brightness=60%	20-100%	5%	Adjust LED button brightness only-Not for the screen display LCD

E Calibration		Brewer Sensors and Keypad			
POSITION	Program Items	Factory set Default	Programming Range	Increments	Notes
E1	Ready Temp. Offset	-3°F -2°C	-2° to -9°F -1° to -5° C	1°F 1°C	Compensates output to measured temperature
E2	LLC Sensitivity	NORMAL ("NORMAL" for most water)	HIGH (Biased for reverse osmosis water or very pure water)	NORMAL HIGH	Liquid level control sensitivity. High, 1300Ω is for reverse osmosis water or very pure water.
E3	Slow flow rate from supply	ON	OFF/ON	Toggle +/- YES or NO	Trims fill system for low supply or Flojet use
E4	LT Brew Valve flow rate:	0.95G	0.80-1.09G 1.30-1.90Liter	0.01G 0.05L	Adjusts flow rate
E5	RT Brew Valve flow rate:	0.95G	0.80-1.09G 1.30-1.90Liter	0.01G 0.05L	Adjusts flow rate
E6	LT Bypass Valve flow rate:	0.38G	0.31-0.44G 0.80-1.09Liter	0.01G 0.05L	Adjusts flow rate
E7	RT Bypass Valve flow rate:	0.38G	0.31-0.44G 0.80-1.09Liter	0.01G 0.05L	Adjusts flow rate

Use this formula to compensate for minor discrepancies in actual volume versus programmed volume.
See "PROGRAM" [E4](#) & [E5](#) For valve settings and calibration. Factory set brew valve flow rates are in liter/min

Current setting is the flow from E4,E5, E6, E7 See table above for factory set default flow rates	Default Brew Valve Flow Rate—CBS-1250 Brewers
ACTUAL VOLUME	CBS-1250
PROGRAMMED VOLUME	Gallons/minute
X	Range
CURRENT SETTING	Left Brew Valve FR 0.95 0.80G to 1.09G
=	Right Brew Valve FR 0.95 0.80G to 1.09G
NEW SETTING	Use this formula to determine the correct setting

Use this formula to determine the correct setting

Set FR lower to increase volume; set higher to decrease volume.

F Service Menu		Software & Code View and Settings			
POSITION	Program Items	Factory set Default	Programming Range	Increments	Notes
F1	Display Firmware	2.2.210720	Displays current version		[6/2020]
F2	Display Bootloader	2.0.210317	Displays current version		[6/2020]
F3	Select Model	CBS-1251;1252;1253 Will need reboot	Scroll to brewer model Save & Exit	CBS-1221 CBS-1251, CBS-1252 CBS-1241, CBS-1242 CBS-1251, CBS-1252 CBS-1261, CBS-1262 MBS-1221, MBS-1251 TBS-1221, MBS-1222	NOTE: Overwrites all user settings (See below)
F4	Option Bypass	Yes	NO or YES		
F5	Option BB Lock	Yes	NO or YES		
F8	Backup to USB	NO	Follow prompts	Saves settings	Insert blank USB
F9	Restore From USB		Applies settings from USB		Insert USB Will need reboot
F10	Restore Defaults	NO	NO/YES		Reset to factory
F11	Error Log	Lists up to six codes, in order	1: ; 2: ;3:;4: ;5: ;6: 1=Newest/6=Oldest LAST six errors only	Newest=first Oldest=last	See Error Codes Chart for references
F12	Erase Error Log	NO +		Toggle +/- YES or NO	FACTORY USE ONLY. DO NOT RESET
F13	Service Phone #	Enter as needed			Set phone contact
F14	Override Lt BBS	NO	NO/YES	Toggle +/- YES or NO	Disables brew basket sensor
F15	Override Rt BBS	NO	NO/YES	Toggle +/- YES or NO	Disables brew basket sensor
F16	Override Lt BBL	NO	NO/YES	Toggle +/- YES or NO	Disables brew basket lock
F17	Override Rt BBL	NO	NO/YES	Toggle +/- YES or NO	Disables brew basket lock

F Error Codes

DO NOT CLEAR ERROR CODES UNTIL ERROR IS IDENTIFIED AND CORRECTED

→Contact factory or specialized personnel for error codes

Code	Description	Possible Cause	Corrective Action
001	Software error-error on start up or corrupted software	Improper start-up or shutdown	Restart , if still fault: reload software
002	Internal flash corrupted internal data memory malfunction	Error found in cyclic redundancy check CRC	Restart , if still fault: reload software If not corrected :replace board
050	Short-circuit in temperature probe	Probe failure.	Replace probe.
051	Open temperature probe.	Bad probe connection, or probe failure.	Check all connections. Replace probe if necessary.
100	Initial Fill Error. Initial fill time took longer than expected after powering up.	Water supply flow rate is too low.	Watch for short potting during brew cycle. Investigate cause of low flow rate. (Clogged water filter...)
101	Error on refill- Tank did not refill within expected time. Water flow too slow from main.	Water supply flow rate is too low. (External to brewer.)	Watch for short potting during brew cycle. Investigate cause of low flow rate. (Clogged water filter...)
200	Heating flatline-Tank is boiling	Heater is on, temperature is not rising/dropping	High elevation correction. Bad heaters or temperature probe or position
201	Heater open, high limit thermostat, or Solid State Relay (SSR) fault	Failure of heating element, SSR, high limit or low voltage	Check that ohms range of heater are between 10-80Ω; replace if not. Check for continuity, and if open replace high limit devices. Check if permanently closed and replace SSRs,if necessary.
202	Heater Shorted or Stuck SSR	Heater is off and equipment is heating. SSR is stuck "ON"	Check that ohms range of heater are between 10-80Ω; replace if not. Check if permanently closed SSR may be stuck in ON mode-replace SSR. Test output on solid state relay
255	Keyboard [HID] error	Usually from longer than 10 se contact. Or faulty reassembly after service	Restart , if still fault: reload software. If mechanical: replace module
NO BSKT <u>Insert Brew Basket</u>		Brew basket must be in place This is a SAFETY FEATURE	Insert brew basket into brewer rails to enable brewer

G Counters Brewer Usage, Water Filter Usage, and Statistics

ROLE: [LT]=Permanent total for lifetime of machine; [R]=operator resettable; [User]=Input needed from operator

Position	Counter	Program items	Role	Information	Increments	Notes
----------	---------	---------------	------	-------------	------------	-------

G1-G4 are for water filter maintenance. All beverage equipment must use filtered water and filter cartridges must be monitored for quality

G4	A, S, B	Counter Reset	[User]	NO	Toggle +/- ,Y or N	Resets all resettable counters to zero
G5	A, S, B	Choose Counter		Factory set to BASIC	Basic= B Advanced= A Statistical= S	Stored brewer component activity.. See column 2, Counters , to identify where counters are located.

G10-G15 Number of brews and volumes handled. Available in BASIC counter only (G5)

G10	B	Brewer Volume	[LT]	Dispensed volume	Gallons/Liters	Total of brews and hot water dispensed
G11	B	Brewer Volume	[R]			
G12	B	Lt Brews	[LT]	Left side brew total		
G13	B	Lt Brews	[R]	CBS-1252	Count	Total brews-Left side (CBS-1252 only)
G14	B	Rt Brews	[LT]	Right side brew total		
G15	B	Rt Brews	[R]	CBS-1251&CBS-1252	Count	Total brews-Right side CBS-1251&CBS-1252

G20-G55 component use cycles and volumes handled. Available in ADVANCED counter only (G5)

G20	A	Fill Cycles	[LT]	Hot water tank refill	Count	Cycles of hot water tank refill
G21	A	Fill Cycles	[R]	cycles		
G22	A	Fill Volume	[LT]	Total volume of water		
G23	A	Fill Volume	[R]	for all brews	Gallons/Liters	Quantity of water for brews
G24	A	Lt Brew Cycles	[LT]	Left brew valve		
G25	A	Lt Brew Cycles	[R]	operation on/off	Count	Totalized cycles of valve operation (CBS-1252 only)
G26	A	Lt Brew Volume	[LT]	Left brew valve		
G27	A	Lt Brew Volume	[R]	flow through volume	Gallons/Liters	Totalized volume through left valve (CBS-1252 only)
G28	A	Rt Brew Cycles	[LT]	Right brew valve		
G29	A	Rt Brew Cycles	[R]	operation on/off	Count	Totalized cycles of valve operation CBS-1251&CBS-1252
G30	A	Rt Brew Volume	[LT]	Right brew valve		
G31	A	Rt Brew Volume	[R]	flow through volume	Gallons/Liters	Totalized volume through right valve CBS-1251&CBS-1252
G32	A	Lt Bypass Cycles	[LT]	Left bypass valve		
G33	A	Lt Bypass Cycles	[R]	operation on/off	Count	Totalized cycles of valve operation (CBS-1252 only)
G34	A	Lt Bypass Volume	[LT]	Left bypass valve		
G35	A	Lt Bypass Volume	[R]	flow through volume	Gallons/Liters	Totalized volume through left valve (CBS-1252 only)
G36	A	Rt Bypass Cycles	[LT]			
G37	A	Rt Bypass Cycles	[R]	Count	Count	Totalized cycles of valve operation CBS-1251&CBS-1252
G38	A	Rt Bypass Volume	[LT]	Right bypass valve flow		
G39	A	Rt Bypass Volume	[R]	through volume	Gallons/Liters	Totalized volume through right valve CBS-1251&CBS-1252
G48	A	Lt BBL Cycles	[LT]	Left brew basket lock		
G49	A	Lt BBL Cycles	[R]	flow through volume	Count	Totalized cycles of brew basket lock operation (CBS-1252 only)
G50	A	Rt BBL Cycles	[LT]	Right brew basket lock		
G51	A	Rt BBL Cycles	[R]	operation on/off	Count	Totalized cycles of brew basket lock operation CBS-1251&CBS-1252
G52	A	Heater Cycles	[LT]	ON/OFF switching for		
G53	A	Heater Cycles	[R]	heating elements	Count	Totalized cycles of heater switching
G54	A	Heater On Time	[LT]	Total ON time for		
G55	A	Heater On Time	[R]	heating element	Hour	Totalized heater ON time in hours

G80-G91 See illustration below for batch button positions Available in STATISTICAL counter only (G5)

G80	S	Batch 10 Cycles	[LT]	Menu button selection	Count	Total brews-left side top button (CBS-1252 only)
G81	S	Batch 10 Cycles	[R]	and activation count		
G82	S	Batch 20 Cycles	[LT]	Menu button selection		
G83	S	Batch 20 Cycles	[R]	and activation count	Count	Total brews-left side middle button (CBS-1252 only)
G84	S	Batch 30 Cycles	[LT]	Menu button selection		
G85	S	Batch 30 Cycles	[R]	and activation count	Count	Total brews-left side bottom button (CBS-1252 only)
G86	S	Batch 40 Cycles	[LT]	Menu button selection		
G87	S	Batch 40 Cycles	[R]	and activation count	Count	Total brews-right side top button CBS-1251&CBS-1252
G88	S	Batch 50 Cycles	[LT]	Menu button selection		
G89	S	Batch 50 Cycles	[R]	and activation count	Count	Total brews-right side middle button CBS-1251&CBS-1252
G90	S	Batch 60 Cycles	[LT]	Menu button selection		
G91	S	Batch 60 Cycles	[R]	and activation count	Count	Total brews-right side bottom button CBS-1251&CBS-1252

The brewer will save changes only from the “H” menu. **DO NOT** reboot brewer or toggle ON/OFF-exit as below.

TO EXIT PROGRAMMING & HOW TO SAVE CONTROL SETTING CHANGES

HOW TO SAVE CHANGES AND EXIT-*The brewer is in PROGRAMMING mode.*

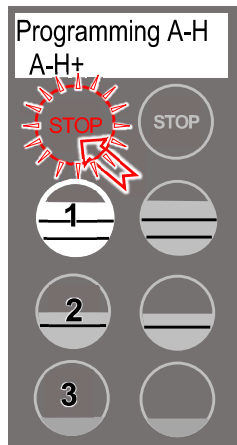

From any screen-
Press STOP button until the EXIT (“H”) screen appears

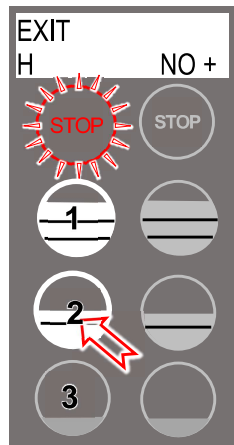

From the “H” screen
Press button **2** to toggle to the EXIT-**YES** screen

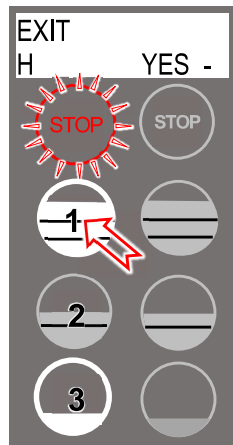

From EXIT screen
Press button **1** to toggle to the SAVE screen

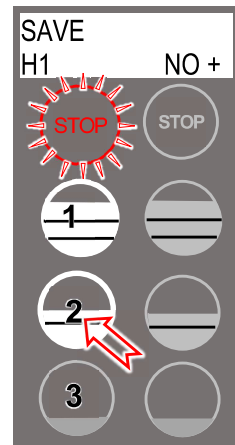

From SAVE screen
Press button **2**, to toggle to the SAVE-**YES** screen

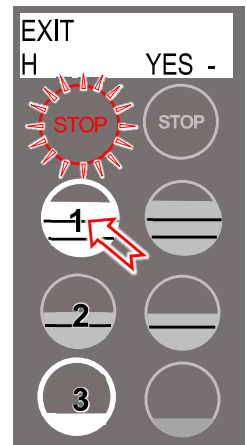

To SAVE and EXIT
Press button **1** to SAVE your changes and EXIT

NOTE: User Settings will be erased and overwritten to factory default settings by the following five programming changes

- 1) When setting or changing units of display for the tank temperature (F Fahrenheit or C Celsius). **(SETTING B4)**
- 2) When setting or changing units of display for the volume (L liters, G gallons). **(SETTING B5)**
- 3) When setting brewer model →The software sets equipment to brewer defaults **(SETTING F3)**
- 4) When loading from USB (Reprograms settings) **(SETTING F9)**
- 5) When restoring defaults (Reloads to defaults) **(SETTING E10)**

Operator Training

Review the operating procedures with whoever will be using the brewer.

Pay particular attention to the following areas:

1. Always pre-heat the dispensers before the first use of each day by filling them halfway with hot water and letting them stand for at least 5 minutes.
2. Do not remove the brew basket from a coffee brewer until it has stopped dripping.
3. Make sure the dispenser is empty before brewing into it.
4. Show how to attach covers, close, and or secure the dispensers for transporting.
5. Show the location and operation of the water shut off valve as well as the circuit breaker for the brewer.
6. Steam from the tank will form condensation in the vent tubes. This condensation will drip into and then out of the brew baskets. Up to 1/4 cup/118cc discharging overnight is possible. Place an appropriate container under each brew basket when not in use.
7. We recommend leaving the power to the brewer on overnight. The water tank is well insulated and very little electricity is used to keep the tank hot. Leaving the brewer in the "ON" position will also avoid delays at the beginning of shifts for the brewer to reach operating temperature.

Cleaning & Maintenance

After Each Brew:

1. Dispose of grounds and rinse brew basket.
2. Never strike a brew basket or hit it against a hard surface.
This will damage the brew cone, and may damage the brew basket support rails
3. Rinse dispensers before reuse.

Every Day:

1. Wash brew basket with hot sudsy water.
2. Pull CSD from the spray head, it is magnetically attached. Use gloves or a heavy towel. → Wash off any film and reattach. Use vinegar if limescale filming is present.
3. Clean dispensers with hot suds water and a brush, rinse and air dry.
4. Use only a soft cloth and hot suds on the outside to avoid scratches. Never use abrasives that will scratch surface.

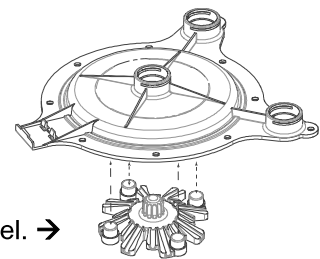

Weekly

1. Use a commercial coffee dispenser cleaner such as URNEX™, TABZ™, DIP-IT™ or Squeak 'n Clean™.
2. Carefully Follow the instructions supplied with the cleaning product
3. Never use spray cleaners, solvent, solvent based cleaner or petroleum based polish anywhere on dispensers

Warning

1. Turn off power before any cleaning procedure, including wiping the exterior for appearance reasons.
2. Dry the exterior, especially the face panel, before turning on power.
3. Do not apply any type of spray cleaner on the face panel of this equipment.
4. Never use solvent or solvent-based cleaner or petroleum based polish anywhere on this equipment.
5. Dry the face of the touch pad before turning on power
6. Do not electrically energize this equipment or attempt operation without all covers in place and all screws fastened.
7. Unplug machine before disassembly or servicing.

Safety Notes

1. Professional installation is required. This appliance is manufactured only for commercial use
2. Operational requirements and maintenance for commercial cooking appliances differ from household appliances.
3. Operators must be trained for this equipment and must understand the use, maintenance and hazards.
4. Access to the service area is restricted to persons having safety/hygiene knowledge and practical experience of the coffee brewer. This appliance must be installed in locations where it can be overseen by adult trained personnel.
5. Do not attempt to move hot beverage equipment once it is filled. Drain equipment before moving.
6. FETCO commercial coffee brewers prepare large amounts of coffee or tea in a single batch using very hot water
7. Commercial coffee brewers provide very hot water from the spray head, brew basket and faucet when it is pulled.
8. Coffee brewers may continue to dispense very hot water from the mechanically operated faucet after the electronic touchpad is completely disabled by turning off the power switch on the lower back of the unit or unplugging the unit.
9. For safety, the brewer control locks the brew basket for 6.0 minutes after starting the brew.
10. Never attempt to defeat the factory set (default) time that the brew basket is locked for safety from start of brew.

Keep these instructions for training and future reference.

General:

1. If not installed correctly by qualified personnel, the brewer will not operate properly, and damage may result.
2. Utilize only qualified beverage equipment service technicians for service and installation.
3. Always have an empty dispenser under spray head of all coffee brewing equipment-including when at idle
4. Damages resulting from improper installation are not covered by the warranty and will void the warranty.
Below are the key points to consider before installation:

Electrical:

1. All CBS_Series brewers require **an electrical ground wire**. Installation without grounding is dangerous.
2. Note Equipotentiality Terminal, if present, (To identify the terminals which, when connected together, bring the various parts of equipment or of a system to the same potential, not necessarily being the earth (ground) potential, e.g. for local bonding.)
3. Verify voltages, polarity, circuits, and circuit breaker access before attaching equipment.
4. Brewers in this series wire differently in regard to a neutral wire. Review the wire diagrams.
5. The electrical diagram is located in the User's Guide and online at www.fetco.com.
6. Make sure of the tight grounding of the equipment and use the external ground bolt.
7. The installation must comply with applicable federal, state, and local codes having jurisdiction at your location. Check with your local inspectors to determine what codes will apply.

→See wiring diagrams on pages 29-31 for connections



Plumbing:

1. North America: All installations must comply with applicable federal, state, or local plumbing codes.
2. All Others: The water and waste piping and connections shall comply with the International Plumbing Code, International Code Council (ICC), or to the Uniform Plumbing Code (IAPMO).
3. Install a backflow prevention device. Most municipalities require a recognized backflow preventer
Usable on all hot beverage and cold beverage equipment is a WATTS® SD-2 or SD-3.
WATTS spring loaded double check valve models are accepted by most zoning authorities.
→The check valve should be as close to the water supply inlet of the beverage equipment as possible
4. All beverage equipment must use a water filter. A finishing carbon filter is preferred
5. Install the filter unit after a water shutoff valve and in a position to facilitate filter replacement.
6. The water line and newly installed filter cartridge must be flushed thoroughly prior to connecting it to the brewer to prevent debris from contaminating the machine
7. Verify that the water line will provide a flow rate of at least 1½ gpm/(5.7lpm) per minute and the water pressure is between 20-75 psig (138-517kPa) before making any connections
8. Only use the supplied factory fitting to attach water supply line to brewer (shipped in brew basket)
9. The supplied fitting is a 3/8" flare/compression fitting for 1/4" supply line. Other adaptors may be substituted.
10. Hand tighten the factory fitting when connecting the stub on the brewer. This will reduce stress on the internal connections and reduce the possibility of leaks developing after the install has been completed

Tank Drain

The water tank must be drained before maintenance procedures, and when the unit is to be relocated or shipped. Drain is for service use only and must not be permanently connected. NOTE: Never plumb a water line to the drain.

1. Disconnect power and water to unit. DANGER: Ensure that all utility connections to the brewer are broken.
2. Move the unit near a sink or obtain a container large enough to hold four gallons of water.
→Note: The CBS-1251 hot water tank when full holds 6.5 gallons; the CBS-1252 11.1 gallons.
3. Remove the front panel and tank cover and allow the tank to cool to a safe temperature
4. The tank drain line and clamp are located inside-under the hot water tank. Pinch the drain line clamp to close
5. Locate the fill valve against the back wall, using pliers, loosen the hose clamp and move it back over the tube.
→Note Do not loosen the hose clamp to the bottom of the hot water tank
6. Crimp the tube an inch or two away from the drain plug to prevent water from flowing and pull it off the valve.
7. Pull the tube end out of the brewer and position over sink or bucket.
8. Release the crimped tube and hose clamp and allow the water to flow into the sink or container.
9. Reverse steps 4-8 when service is complete. Ensure pinch clamp is open and hose clamps are in place.

Brewer	Hot Water Tank Capacity	OPEN Leave open for use	
CBS-1251 Single	6.5 gal 24.4 liter	PINCH SHUT To drain tank & service brewer	
CBS-1252 Twin	11.1 gal 42.1 liter		

Installation safety and hygiene directions-For International and CE equipment

1. Access to the service area is restricted to persons having safety/hygiene knowledge and practical experience of the coffee brewer. This appliance must be installed in locations where it can be overseen by trained personnel.
2. For proper operation, this appliance must be installed indoors where the temperature is between 10°C/50°F to 35°C/95°F. Drain and remove all liquid from equipment and lines if exposed to freezing temperatures.
3. All commercial cooking equipment, including this unit, is not intended for use by children or persons with reduced physical, sensory, or mental capabilities. Ensure proper supervision of children and keep them away from the unit.
4. Children should be supervised to ensure that they do not play around hot beverage equipment.
5. This unit must be installed and serviced by qualified personnel only.
6. Installation must conform to all local electrical and plumbing codes. Installation by unqualified personnel will void the unit warranty and may lead to electric shock or burn, as well as damage to unit and/or its surroundings.
7. If the power cord requires repair or replacement-it must be performed by the manufacturer or authorized service personnel with the specified cord only from the manufacturer in order to avoid a hazard.
8. Review the dimensions for the unit and verify that it will fit properly in the space intended for it. Verify that the counter or table will support the total weight of the brewer and dispensers when filled (See: Technical Data).
9. Place the brewer on the counter or stand. When the brewer is in position, level it front to back as well as side-to-side by adjusting the legs.
10. Brewers will need a sturdy supported surface for operation. Do not move brewers when filled.
11. Do not tilt appliance more than 10° to insure safe operation.
12. Unit is for protected indoor use only. Do not steam clean or use excessive water on unit.
13. This unit is not "jet-proof" construction. Do not pressure wash or use jet spray to clean this unit.
14. The unit is not waterproof-do not submerge or saturate with water.

**Equipment exposed to flood and contaminated must not be used due to electrical and food safety.
Do not operate if unit has been submerged or saturated with water.**

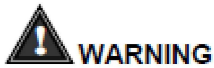

WARNING

All electrical connections must be in accordance with local electrical codes and any other applicable codes. If the supply cord is damaged, it must be replaced by the manufacturer, its service agent, or similarly qualified persons in order to avoid a hazard.

To prevent an electric shock hazard this device must be bonded to equipment in close proximity with an equipotential bonding conductor. This device is equipped with a bonding lug for this purpose and is marked with the following symbol



	WARNING	To reduce risk of electric shock or fire.
	FETCO® Hot Beverage Equipment is for commercial use only.	
	Do not remove or open cover. No user serviceable parts inside. Refer installation and service to qualified personnel.	
	Caution, disconnect from power supply before servicing.	
	GROUND: National Electrical Code requires separate grounding wire.	
	Use dedicated circuit with capacity rated by local code or National Electrical Code for the current draw of this equipment. Check serial number plate on right side for power requirements.	
	Locate unit away from source of heat. Do not install or use near combustibles.	
	THIS APPLIANCE IS ENERGIZED WHENEVER IT IS CONNECTED TO A POWER SOURCE	
	FAILURE TO COMPLY RISKS EQUIPMENT DAMAGE, PROPERTY DAMAGE, FIRE, OR SHOCK HAZARD	
Notice	This equipment must be installed with a backflow protection device to comply with federal, state or local municipality codes.	
Notice	Read the user guide before installing and operating this unit.	

Labels and warnings for hot beverage equipment

For BACK PANEL of equipment (1046.00035.00)

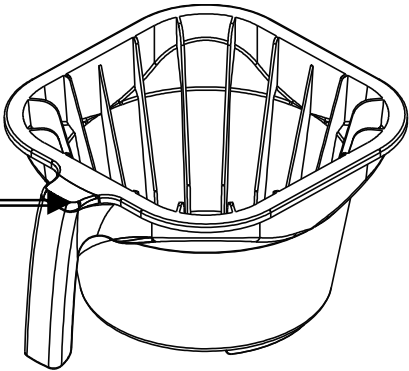
Complete Brew Basket		Part Number B015280BN2BK 0.280" diameter hole	
<p>Brew basket handle plug for polymeric brew baskets is available in optional colors.</p> 	Part Number	Plug Insert color	
	1023.00195.00	BROWN PLUG, BB HANDLE	
	1023.00194.00	BLACK PLUG, BB HANDLE	
	1023.00190.00	RED PLUG, BB HANDLE	
	1023.00191.00	GREEN PLUG, BB HANDLE	
	1023.00192.00	ORANGE PLUG, BB HANDLE	
	1023.00180.00	BLUE PLUG, BB HANDLE	

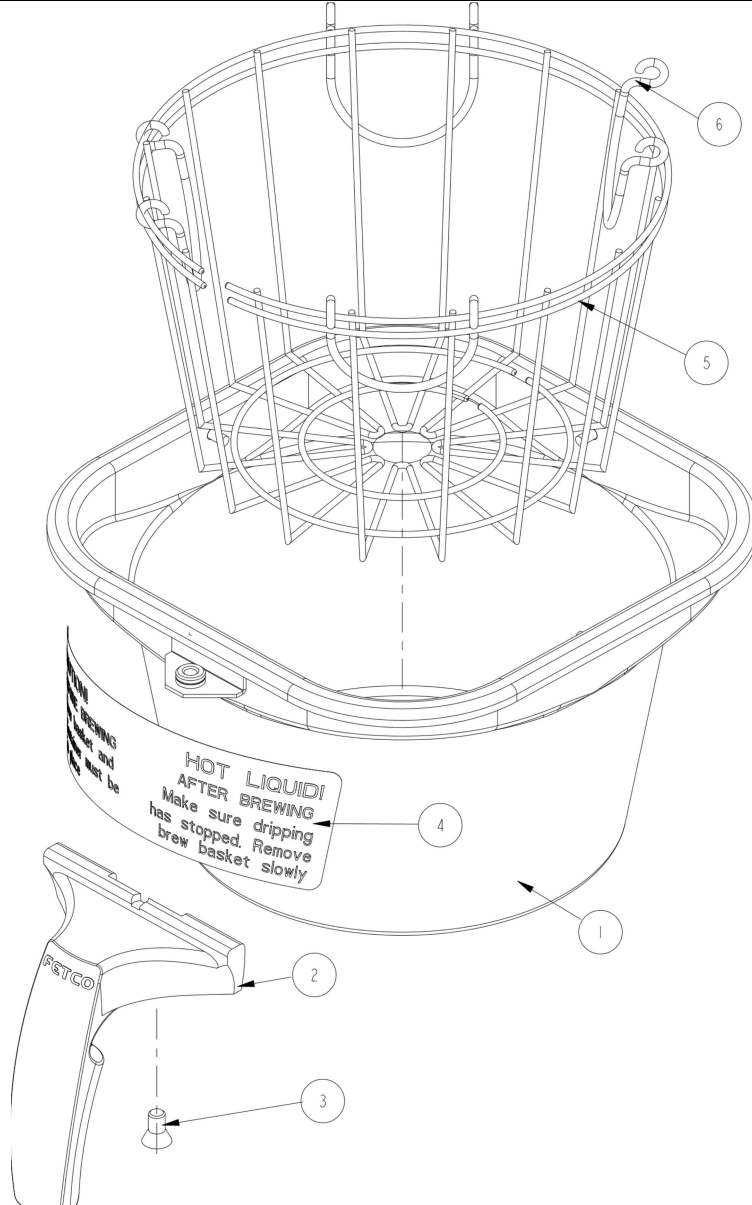
	Stainless Steel Brew Basket		
	Ref#	Part Number	Description
	←	B001280B1	Complete Stainless Steel Brew basket <u>no clips</u> (Standard)
		B002280B1	Complete Stainless Steel Brew basket <u>with clips</u> (Optional)
	1	1112.00058.00	BB brew cone W/LDMNT
	2	1046.00025.00	BREW BASKET WARNING LABEL
	3	1082.00040.00	SCREW, 1/4-20 X .5, FL HD, PH., W/NYLN
	4	1009.00005.00	WIRE BASKET
	5	1102.00064.00	HANDLE W/MAGNET ASY, BLACK
	6	1009.00003.00	CLIP, WIRE BASKET, NOTE! Requires 4 clips
	Optional colored handle	1102.00065.00	HANDLE W/MAGNET ASY, RED
	Optional colored handle	1102.00066.00	HANDLE W/MAGNET ASY, GREEN
	Optional colored handle	1102.00067.00	HANDLE W/MAGNET ASY, ORANGE

Parts Diagram CBS-1251

Drawing 1101.00572.00
Parts CBS-1251

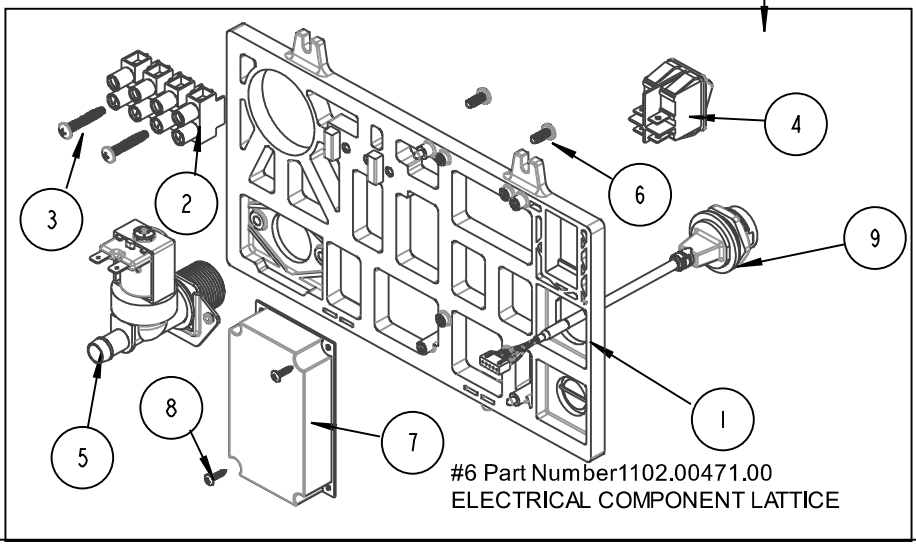
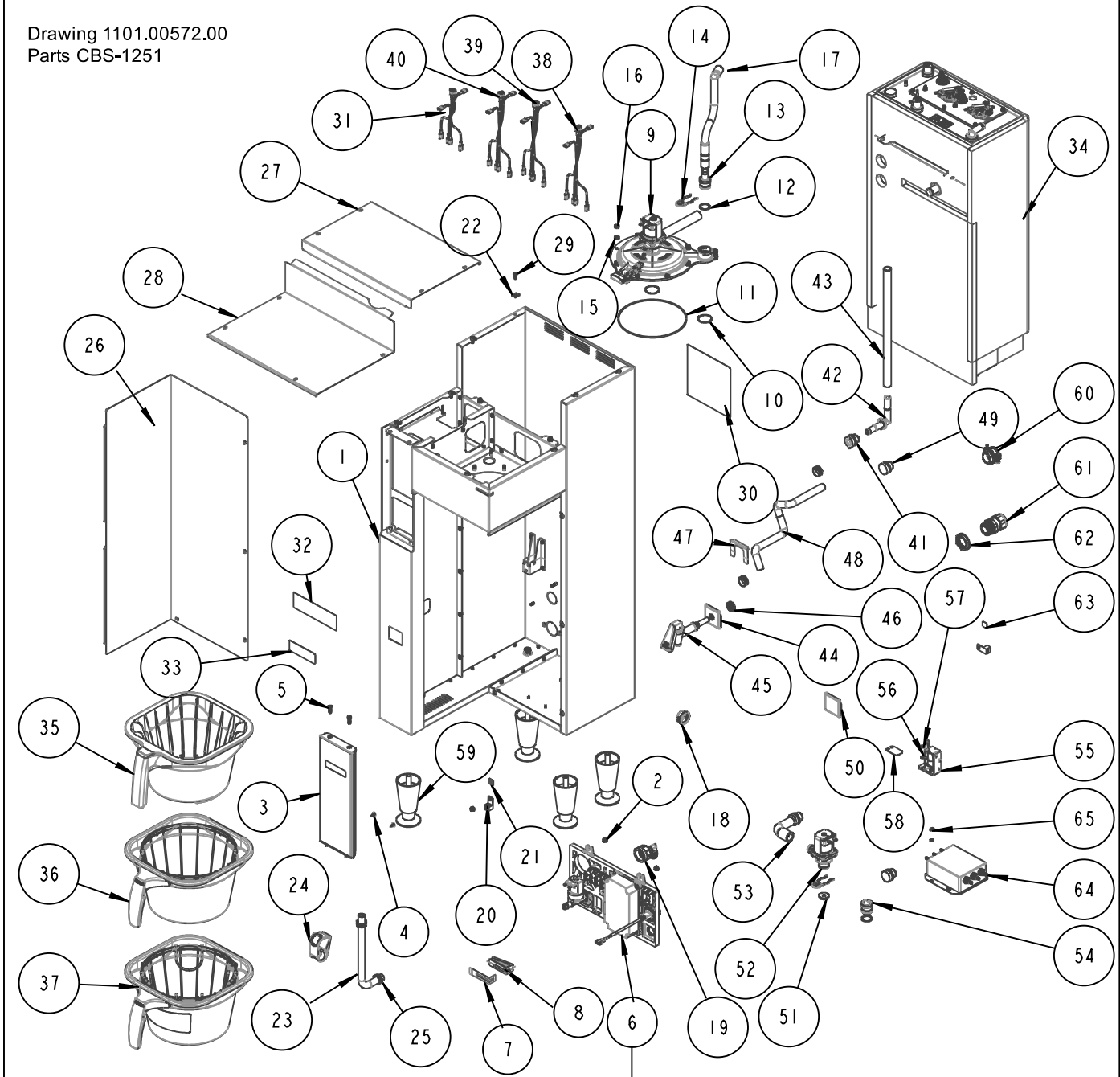

Ref	Qty	Part Number	Description Drawing 1101.00572.00, CBS-1251
1	1	1111.00100.00	WELDMENT BODY, CBS-2251
2	6	1084.00051.00.	NUT, HEX LOCKWASHER, #8-32, 18-8 ST. STL
3	1	1102.00480.00	FRONT PANEL ASSY, SINGLE, PLUS SERIES
4	2	1082.00029.00	SCREW, #6 X 3/8 LG, TRUSS HD PHIL, SHEET MTL
5	2	1082.00058.00	SCREW, # 8-32 X 5/8, FLAT HD, PH, 18-8 SS
6	1	1102.00471.00	ELECTRICAL COMPONENT LATTICE, NEXT GEN XV+
6 REF	1	Reference	ELECTRICAL COMPONENT LATTICE, NEXT GEN XV+
6-1	1	1023.00350.00	ELECTRICAL MOUNTING LATTICE, COMMON
6-2	1	1052.00023.00	EUROSTRIP HE16 TERM. BLOCK, 4 POLE, 63 AMP, 18-8 AWG
6-3	2	1082.00056.00	SCREW, # 8-16 x 1" PAN HD PHIL, THREAD FORMING, FOR PLASTICS, 18-8 SS
6-4	2	1058.00024.00	SWITCH, POWER, DOUBLE POLE, 16A, 125/250 VAC
6-5	4	1057.00043.00	SOLENOID VALVE, 5.5L/min, 180 DEG, 24VDC
6-6	2	1082.00010.00	SCREW, PAN HD. PHIL. MACH., M4x10 ZINC-PLATED
6-7	1	1052.00059.00	POWER SUPPLY, 90-264VAC/24VDC, 2.25A
6-8	2	1082.00020.00	SCREW, #6 X 5/8, TRUSS HD PHIL, SHEET MTL
6-9	2	1058.00055.00	USB CONNECTOR
7	1	1097.00171.00	ADHESIVE, RGB LED BAR
8	1	1023.00390.00	LENS, LIGHT BAR, BLACK
9	1	1102.00450.00	QUICK CONNECT SRAYHEAD ASSEMBLY, BASIC [See Page 24 for expanded drawing]
10	2	1024.00107.00	O-RING, 1 3/16" OD X 1 1/16" ID X 1/16" TH, BYPASS SEAL
11	1	1024.00108.00	O-RING, 5 11/16"OD X 5 1/2" ID X 3/32" TH, BREW SEAL
12	2	1024.00106.00	O-RING, 13/16"OD X 11/16"ID X 1/16" TH, FOR QUICK CONNECT
13	1	1023.00343.00	VENT INSERT, QUICK CONNECT
14	2	1023.00342.00	QUICK CONNECT CLIP
15	10	1083.00010.00	WASHER, #10 SCREW W/NEOPRENE-BONDED SEAL
16	10	1084.00006.00	NUT, 8-32 18-8 HEX MACHINE SCREW
17	1	1024.00098.00	VENT TUBE, CBS- EXTRACTOR SERIES
18	1	1086.00004.00	BUSHING, SNAP, 1" MOUNTING HOLE
19	1	1102.00243.00	ADAPTER ASSY, 3/4" BSP x 1/4" NPT x 3/8" TUBE
20	2	1065.00009.00	GROUND LUG CONNECTOR, 14-2 AWG, ALUMINUM
21	1	1044.00012.00	LABEL GROUND, CE
22	12	1084.00011.00	NUT, CLIP ON (J-NUT), #6-32, 22-20 GA., BLK-PH FINISH
23	1	1025.00058.00	TUBE, 9/16"OD X 5/16"ID X 25.00"LG
24	1	1086.00009.00	CLAMP, 3/4" MAX TUBE OD FLOW CONTROL
25	4	1086.00003.00	UNICLAMP, 15.9 HOSE OD CLAMP
26	1	1112.00529.00	WELDMENT FRONT COVER, CBS-2250
27	1	1001.00402.00	COVER TOP, CBS-2251
28	1	1001.00403.00	COVER, UPPER BASE, CBS-2251
29	12	1082.00017.00	SCREW, TRUSS HD. PHIL. MACHINE, # 6-32 X 1/2 LG.
30	1	1046.00035.00	LABEL, WARNING "TO REDUCE RISK OF ELECTRIC SHOCK OR FIRE"
31	1	1402.00097.10	WIRE HARNESS, CBS-1240/50, LOW AMP, UNIVERSAL
32	1	1046.00003.00	LABEL, CSD WARNING, 1.5" X 5.0"
33	1	1041.00033.00	BLACK EXTRACTOR PLUS LABEL, LASER ENGRAVED
34	1	1104.00165.00	TANK ASSEMBLY, CBS-2251, 1 X 4KW/240VAC [See additional pages for expanded drawing]
34	1	1104.00166.00	TANK ASSEMBLY, CBS-2251, 1 X 5KW/240VAC
34	1	1104.00167.00	TANK ASSEMBLY, CBS-2251, 2 X 2.3KW/240VAC
34	1	1104.00168.00	TANK ASSEMBLY, CBS-2251, 2 X 3KW/240VAC
35	1	B015280BN2BK	BREW BASKET ASSY, 16" X 6", 0.280" DIA HOLE, BROWN PLUG
36	1	B001280B1BB	ASSY, 16" X 6", 0.280 DIA HOLE, BLACK
37	1	B002280B1BB	ASSY, 16" X 6", 0.280" DIA HOLE, BLACK
38	1	1402.00037.10	HARNESS HIGH AMP, CBS-2232/42/51, UL
39	1	1402.00039.10	HARNESS HIGH AMP, CBS-2231/41/51, UL
40	1	1402.00121.10	WIRE HARNESS ADDITION, HIGH AMP, EMI FILTER, 2-POLE, CE
41	1	1024.00111.00	GROMMET, SILICONE, W/ POSITION TABS
42	1	1023.00362.00	FITTING VENT, ELBOW, .375" X .375", SELF POSITIONING
43	1	1013.00131.00	TUBE, 304SS, .625OD X .065 WALL X 11-1/2" LG.
44	1	1023.00348.00	HOT WATER INSERT, MANUAL FAUCET
45	1	1071.00055.00	FAUCET, HOT WATER, PSC-BR-8, WITH FLAT AND STEM
46	1	1084.00048.00	JAM NUT, 1/2-20 UNF, NICKEL PLATED BRASS
47	1	1003.00370.00	HOT WATER INSERT LOCK
48	1	1025.00120.00	TUBE, 9/16"OD X 5/16"ID X 13.00"LG
49	2	1024.00051.00	GROMMET, SILICONE, BLANK
50	1	1023.00349.00	HOT WATER INSERT, NO FAUCET
51	1	1023.00369.00	ORIFICE INSERT, QUICK CONNECT, 3/16" HOLE
52	1	1057.00076.00	VALVE ASSEMBLY, COMPLETE, NG, DELTROL
53	1	1029.00042.00	BYPASS L-TUBE, SILICONE, 2200 SINGLE SERIES
54	1	1023.00344.00	PLUG INSERT, QUICK CONNECT
55	1	1102.00219.00	ASSEMBLY, BB LOCKER, 24VDC
56	6	1083.00009.00	WASHER, #6 SCREW, INTL TOOTH LOCKWASHER
57	2	1084.00010.00	NUT, HEX, #6-32, UNDERSIZED, ZINC PLATED
58	1	1003.00259.00	BRACKET, BREW BASKET LOCK COVER
59	4	1073.00007.00	LEG, FLANGE FOOT, 4" HIGH
60	1	1086.00008.00	CONNECTOR, CLAMP, NON-METALLIC CABLE, 3/4"
61	1	1086.00031.00	SKINTOP, 3/4" NPT, 0.354" - 0.630" DIA CABLE, BLK
62	1	1086.00032.00	LOCKNUT, SKINTOP, 3/4" NPT, BLACK HEX
63	1	1044.00013.00	LABEL EQUIPOTENTIALITY, CE
64	1	1052.00027.00	EMI FILTER, THREE LINE 30A, 250/440VAC
65	4	1084.00012.00	NUT, HEX, #6-32 MACHINE SCREW

Parts Diagrams CBS-1252 and CBS-1253

Parts lists for
 CBS-1252 1-1/2 gallon
 Drawing 1101.00573.00
 CBS-1252 2 gallon
 Drawing 1101.00592.00

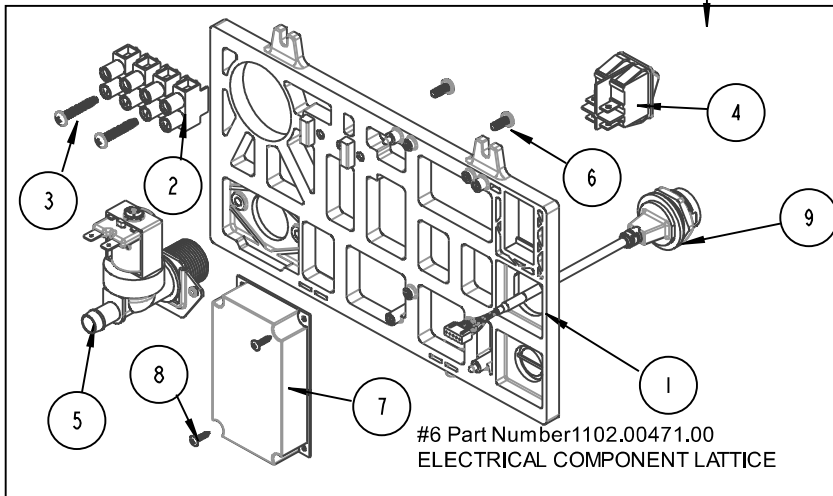
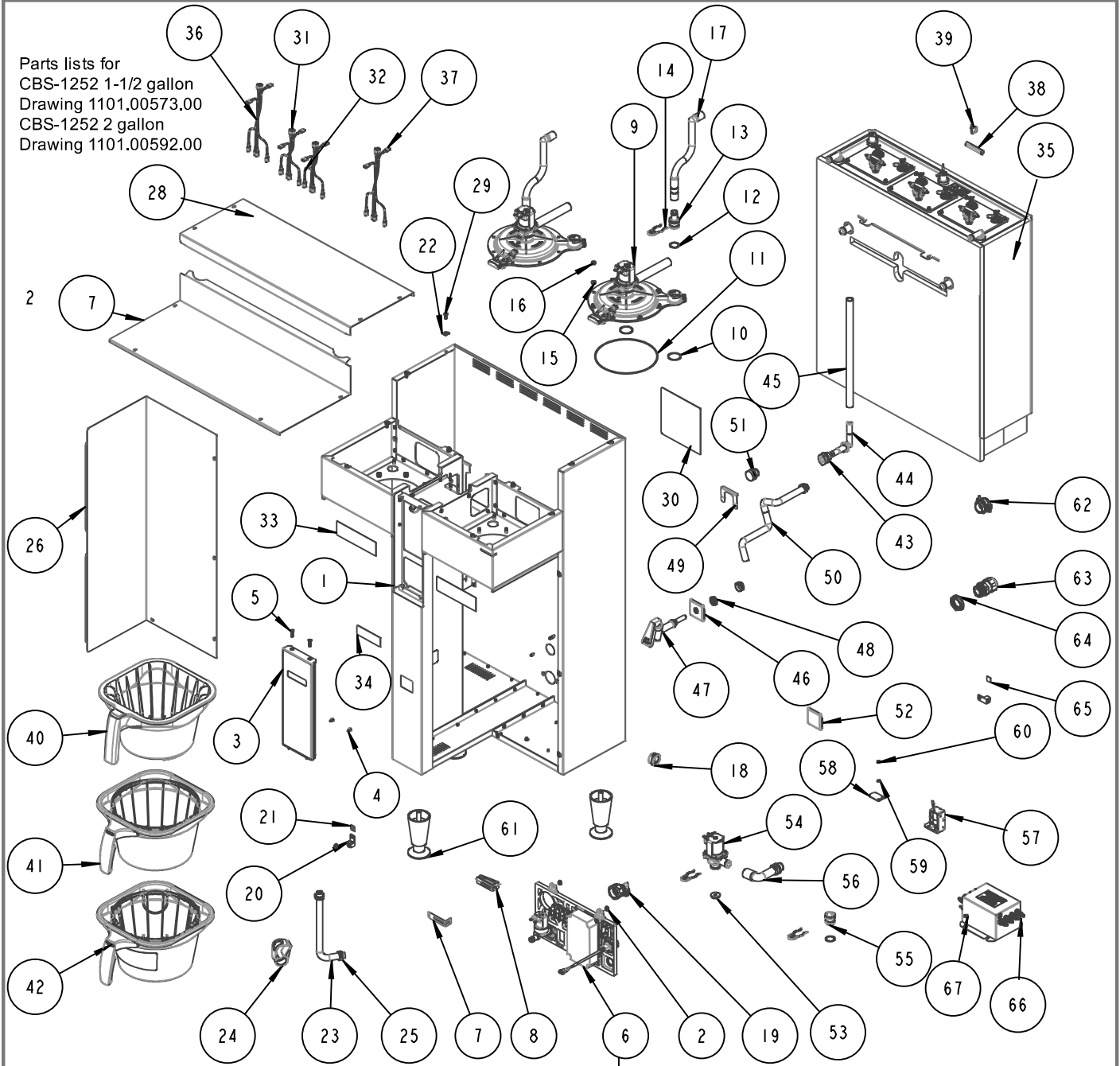

REF	QTY	Part number	Description	Drawing 1101.00573.00, 1101.00059.00 Parts CBS-1252 and applies to CBS-1253
1	1	1111.00099.00	WELDMENT BODY, CBS-2252	1 1/2 gallon brewer only
1	1	1111.00114.00	WELDMENT BODY, CBS-2252	2 gallon brewer only
2	6	1084.00051.00	NUT, HEX LOCKWASHER, #8-32, 18-8 ST. STL.	
3	1	1102.00470.00	FRONT PANEL ASSY, DOUBLE, PLUS SERIES	
4	2	1082.00029.00	SCREW, #6 X 3/8 LG, TRUSS HD PHIL, SHEET MTL	
5	2	1082.00058.00	SCREW, # 8-32 X 5/8, FLAT HD, PH, 18-8 SS	
6 REF	1	Reference	ELECTRICAL COMPONENT LATTICE, NEXT GEN XV+	
6-1	1	1023.00350.00	ELECTRICAL MOUNTING LATTICE, COMMON	
6-2	1	1052.00023.00	EUROSTRIP HE16 TERM. BLOCK, 4 POLE, 63 AMP, 18-8 AWG	
6-3	2	1082.00056.00	SCREW, # 8-16 x 1" PAN HD PHIL, THREAD FORMING, FOR PLASTICS, 18-8 SS	
6-4	2	1058.00024.00	SWITCH, POWER, DOUBLE POLE, 16A, 125/250 VAC	
6-5	4	1057.00043.00	SOLENOID VALVE, 5.5L/min, 180 DEG, 24VDC	
6-6	2	1082.00010.00	SCREW, PAN HD, PHIL. MACH., M4x10 ZINC-PLATED	
6-7	1	1052.00059.00	POWER SUPPLY, 90-264VAC/24VDC, 2.25A	
6-8	2	1082.00020.00	SCREW, #6 X 5/8, TRUSS HD PHIL, SHEET MTL	
6-9	2	1058.00055.00	USB CONNECTOR	
7	1	1097.00171.00	ADHESIVE, RGB LED BAR	
8	1	1023.00390.00	LENS, LIGHT BAR, BLACK	
9	2	1102.00450.00	QUICK CONNECT SRAYHEAD ASSEMBLY, BASIC [See Page 24 for expanded drawing]	
10	4	1024.00107.00	O-RING, 1 3/16" OD X 1 1/16" ID X 1/16" TH, BYPASS SEAL	
11	2	1024.00108.00	O-RING, 5 11/16"OD X 5 1/2" ID X 3/32" TH, BREW SEAL	
12	3	1024.00106.00	O-RING, 13/16"OD X 11/16"ID X 1/16" TH, FOR QUICK CONNECT	
13	2	1023.00343.00	VENT INSERT, QUICK CONNECT	
14	4	1023.00342.00	QUICK CONNECT CLIP	
15	20	1083.00010.00	WASHER, #10 SCREW W/NEOPRENE-BONDED SEAL	
16	20	1084.00006.00	NUT, 8-32 18-8 HEX MACHINE SCREW	
17	2	1024.00098.00	VENT TUBE, CBS- EXTRACTOR SERIES	
18	2	1086.00004.00	BUSHING, SNAP, 1" MOUNTING HOLE	
19	1	1102.00243.00	ADAPTER ASSY, 3/4" BSP x 1/4" NPT x 3/8" TUBE	
20	2	1065.00009.00	GROUND LUG CONNECTOR, 14-2 AWG, ALUMINUM	
21	1	1044.00012.00	LABEL GROUND, CE	
22	12	1084.00011.00	NUT, CLIP ON (J-NUT), #6-32, 22-20 GA., BLK-PH FINISH	
23	1	1025.00058.00	TUBE, 9/16"OD X 5/16"ID X 25.00"LG	
24	1	1086.00009.00	CLAMP, 3/4" MAX TUBE OD FLOW CONTROL	
25	4	1086.00003.00	UNICLAMP, 15.9 HOSE OD CLAMP	
26	1	1112.00529.00	WELDMENT FRONT COVER, CBS-2250	1 1/2 gallon brewer and 2 gallon brewer
27	1	1001.00352.00	COVER, UPPER BASE, CBS-1152 EXTRACTOR V+	
28	1	1001.00399.00	COVER TOP, CBS-2252	
29	12	1082.00017.00	SCREW, TRUSS HD. PHIL. MACHINE, # 6-32 X 1/2 LG.	
30	1	1046.00035.00	LABEL, WARNING "TO REDUCE RISK OF ELECTRIC SHOCK OR FIRE"	
31	1	1402.00097.10	WIRE HARNESS, CBS-1240/50, LOW AMP, UNIVERSAL	
32	1	1402.00097.11	WIRE HARNESS ADDITION, CBS-1252, LOW AMP, UNIVERSAL	
33	2	1046.00003.00	LABEL, CSD WARNING, 1.5" X 5.0"	
34	1	1041.00033.00	BLACK EXTRACTOR PLUS LABEL, LASER ENGRAVED	
35	1	1104.00160.00	TANK ASSEMBLY, CBS-2252, 3 X 3KW/240VAC	[See additional pages for expanded drawing]
35	1	1104.00161.00	TANK ASSEMBLY, CBS-2252, 2 X 3KW/240VAC	[See additional pages for expanded drawing]
35	1	1104.00162.00	TANK ASSEMBLY, CBS-2252, 3 X 4KW/240VAC	[See additional pages for expanded drawing]
35	1	1104.00163.00	TANK ASSEMBLY, CBS-2252, 3 X 5KW/240VAC	[See additional pages for expanded drawing]
35	1	1104.00164.00	TANK ASSEMBLY, CBS-2252, 2 X 5KW/240VAC	[See additional pages for expanded drawing]
36	1	1402.00112.10	WIRE HARNESS, CBS-1252/61, HIGH AMP, 1 OR 3PH, 3 HEATERS, UL	
37	1	1402.00120.10	WIRE HARNESS, 3 HEATER, HIGH AMP, 3L-N-PE, 220/380-240/415, INTL/CE	
38	1	1022.00032.00	SLEEVE, Ø.50 x 2.0" LG. x 1.50" SLOT	
39	1	1066.00003.00	CABLE TIE, 3-7/8" LG., BLACK	
40	1	B015280BN2BK	BREW BASKET ASSY BLACK, 16" X 6", 0.280" DIA HOLE, BROWN PLUG	
41	1	B001280B1BB	ASSY, 16" X 6", 0.280 DIA HOLE, BLACK	
42	1	B002280B1BB	ASSY, 16" X 6", 0.280" DIA HOLE, BLACK	
43	1	1024.00111.00	GROMMET, SILICONE, W/ POSITION TABS	
44	1	1023.00362.00	FITTING VENT, ELBOW, .375" X .375", SELF POSITIONING	
45	1	1013.00131.00	TUBE, 304SS, .625OD X .065 WALL X 11-1/2" LG.	
46	1	1023.00348.00	HOT WATER INSERT, MANUAL FAUCET	
47	1	1071.00055.00	FAUCET, HOT WATER, PSC-BR-8, WITH FLAT AND STEM	
48	1	1084.00048.00	JAM NUT, 1/2-20 UNF, NICKEL PLATED BRASS	
49	1	1003.00370.00	HOT WATER INSERT LOCK	
50	1	1025.00120.00	TUBE, 9/16"OD X 5/16"ID X 13.00"LG	
51	1	1024.00051.00	GROMMET, SILICONE, BLANK	
52	1	1023.00349.00	HOT WATER INSERT, NO FAUCET	
53	1	1023.00369.00	ORIFICE INSERT, QUICK CONNECT, 3/16" HOLE	
54	1	1057.00076.00	VALVE ASSEMBLY, COMPLETE, NG, DELTROL	
55	1	1023.00344.00	PLUG INSERT, QUICK CONNECT	
56	1	1029.00042.00	BYPASS L-TUBE, SILICONE, 2200 SINGLE SERIES	
57	1	1102.00219.00	ASSEMBLY, BB LOCKER, 24VDC	
58	1	1003.00259.00	BRACKET, BREW BASKET LOCK COVER	
59	2	1083.00009.00	WASHER, #6 SCREW, INTL TOOTH LOCKWASHER	
60	1	1084.00010.00	NUT, HEX, #6-32, UNDERSIZED, ZINC PLATED	
61	3	1073.00007.00	LEG, FLANGE FOOT, 4" HIGH	
62	1	1086.00008.00	CONNECTOR, CLAMP, NON-METALLIC CABLE, 3/4"	
63	1	1086.00031.00	SKINTOP, 3/4" NPT, 0.354" - 0.630" DIA CABLE, BLK	
64	1	1086.00032.00	LOCKNUT, SKINTOP, 3/4" NPT, BLACK HEX	
65	1	1044.00013.00	LABEL EQUIPOTENTIALITY, CE	
66	1	1052.00050.00	EMI FILTER, 25A, 250/440VAC, 50/60Hz	
67	1	1084.00012.00	NUT, HEX, #6-32 MACHINE SCREW	

CBS-1251 Tank Assembly

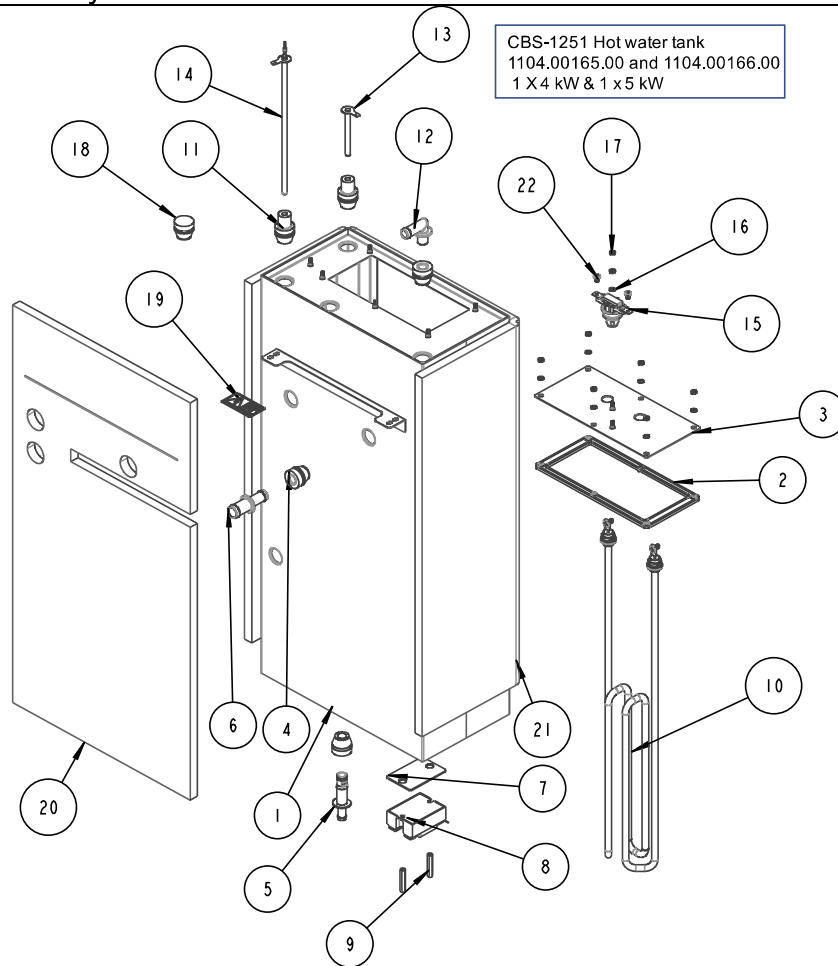

TANK ASSY, CBS-1251 Single Heater Drawing number 1104.000165.00 & 1104.000166.00

REF	QTY	Part number	Description
1	1	1114.00172.00	WELDMENT, TANK, CBS-2251
2	1	1024.00114.00	TANK GASKET - NG HEATER PLATE, TWO ELEMENT
3	1	1114.00184.00	WELDMENT TANK HEATER BRACKET, NG-2231, SINGLE
4	3	1024.00050.00	GROMMET, SILICONE, 11.4mm ID
5	1	1023.00166.00	FITTING, COLD WATER INLET, GROMMET DESIGN
6	1	1023.00203.00	FITTING, STRAIGHT, GROMMET, .625"
7	1	1003.00140.00	ALUMINUM BRACKET FOR SSR
8	1	1052.00033.00	RELAY, SOLID STATE, 50A/480VAC, W/BUILD IN VARISTOR
9	2	1081.00042.00	STANDOFF, 1/4" HEX
10	1	1107.00010.00	HEATER ASSEMBLY, IMMERSION 4kW/240VAC
10	1	1107.00032.00	HEATER ASSEMBLY, IMMERSION, 5kW/240VAC
11	2	1024.00053.00	LEVEL AND TEMP PROBE GROMMET
12	1	1023.00212.00"	FITTING, ELBOW, GROMMET, .500
13	1	1112.00019.00	PROBE WELDMENT, WATER LEVEL 2.600" LG
14	1	1102.00161.00	PROBE ASSEMBLY, TEMP. AND LLC, 8" LONG
15	1	1053.00052.00	THERMOSTAT, SINGLE SHOT, SCREW CONNECTIONS, 240V/25A
16	8	1083.00009.00	WASHER, #6 SCREW, INTL TOOTH LOCKWASHER
17	8	1084.00010.00	NUT, HEX, #6-32, UNDERSIZED, ZINC PLATED
18	1	1044.00004.00	LABEL, DANGER, HIGH VOLTAGE
19	1	1024.00051.00	GROMMET, SILICONE, BLANK
20	1	1022.00068.00	INSULATION, TANK FRONT, CBS-2151
21	1	1022.00069.00	INSULATION, TANK BACK, CBS-2151
22	2	1082.00136.00	BRASS SCREW, #8-32 X 1/4", PHILLIPS PAN HEAD

CBS-1251 Hot water tank
1104.00167.00 and 1104.00168
2 X 2.3 kW & 2 x 3 kW

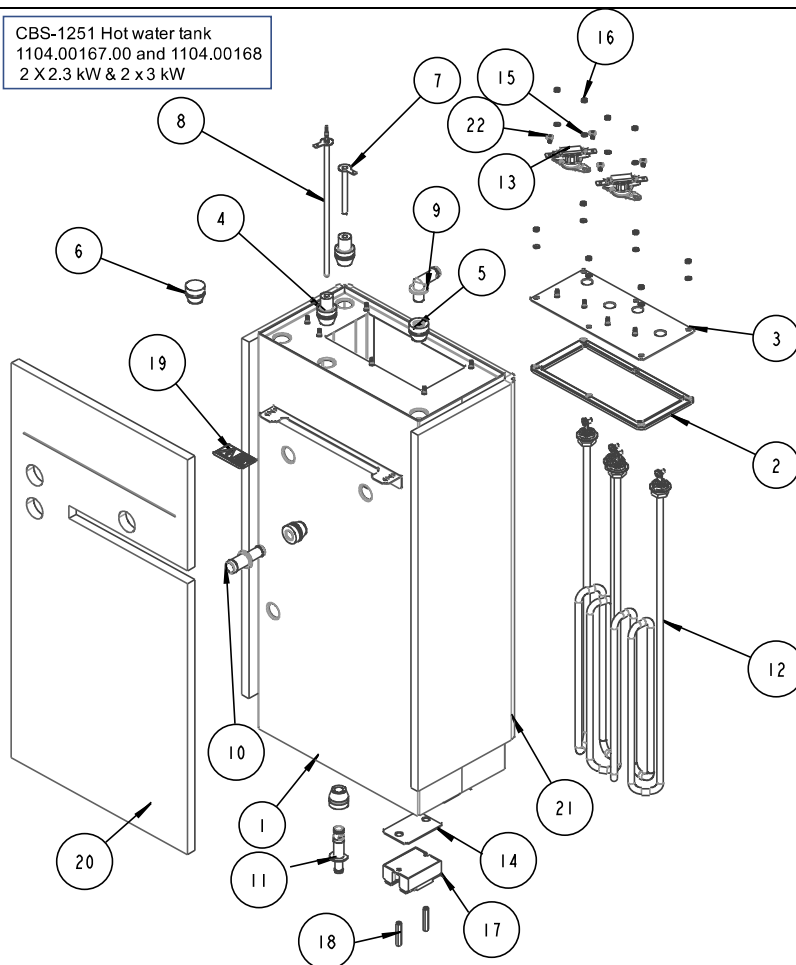

TANK ASSY, CBS-1251 Two Heater Drawing number 1104.000167.00 & 1104.00168.00

REF	QTY	Part number	Description
1	1	1114.00172.00	WELDMENT, TANK, CBS-2251
2	1	1024.00114.00	TANK GASKET - NG HEATER PLATE, TWO ELEMENT
3	1	1114.00176.00	WELDMENT TANK HEATER BRACKET, NG-2231
4	3	1024.00050.00	GROMMET, SILICONE, 11.4mm ID
5	1	1023.00166.00	FITTING, COLD WATER INLET, GROMMET DESIGN
6	1	1023.00203.00	FITTING, STRAIGHT, GROMMET, .625"
7	2	1003.00140.00	ALUMINUM BRACKET FOR SSR
8	2	1052.00033.00	RELAY, SOLID STATE, 50A/480VAC, W/BUILD IN VARISTOR
9	4	1081.00042.00	STANDOFF, 1/4" HEX
10	2	1107.00037.00	HEATER ASSEMBLY, IMMERSION 2300W/240VAC
10	2	1107.00005.00	HEATER ASSEMBLY, IMMERSION 3000W/240VAC
11	2	1024.00053.00	LEVEL AND TEMP PROBE GROMMET
12	1	1023.00212.00	FITTING, ELBOW, GROMMET, .500"
13	1	1112.00019.00	PROBE WELDMENT, WATER LEVEL 2.600" LG
14	1	1102.00161.00	PROBE ASSEMBLY, TEMP. AND LLC, 8" LONG
15	2	1053.00052.00	THERMOSTAT, SINGLE SHOT, SCREW CONNECTIONS, 240V/25A
16	10	1083.00009.00	WASHER, #6 SCREW, INTL TOOTH LOCKWASHER
17	10	1084.00010.00	NUT, HEX, #6-32, UNDERSIZED, ZINC PLATED
18	1	1024.00051.00	GROMMET, SILICONE, BLANK
19	1	1044.00004.00	LABEL, DANGER, HIGH VOLTAGE
20	1	1022.00068.00	INSULATION, TANK FRONT, CBS-2151
21	1	1022.00069.00	INSULATION, TANK BACK, CBS-2151
22	4	1082.00136.00	BRASS SCREW, #8-32 X 1/4", PHILLIPS PAN HEAD

CBS-1252 and CBS1253 Tank Assembly

CBS-1252 Hot water tank
 1104.00161.00; 1104.00164.00
 2 X 3kW; 2x 5 kW

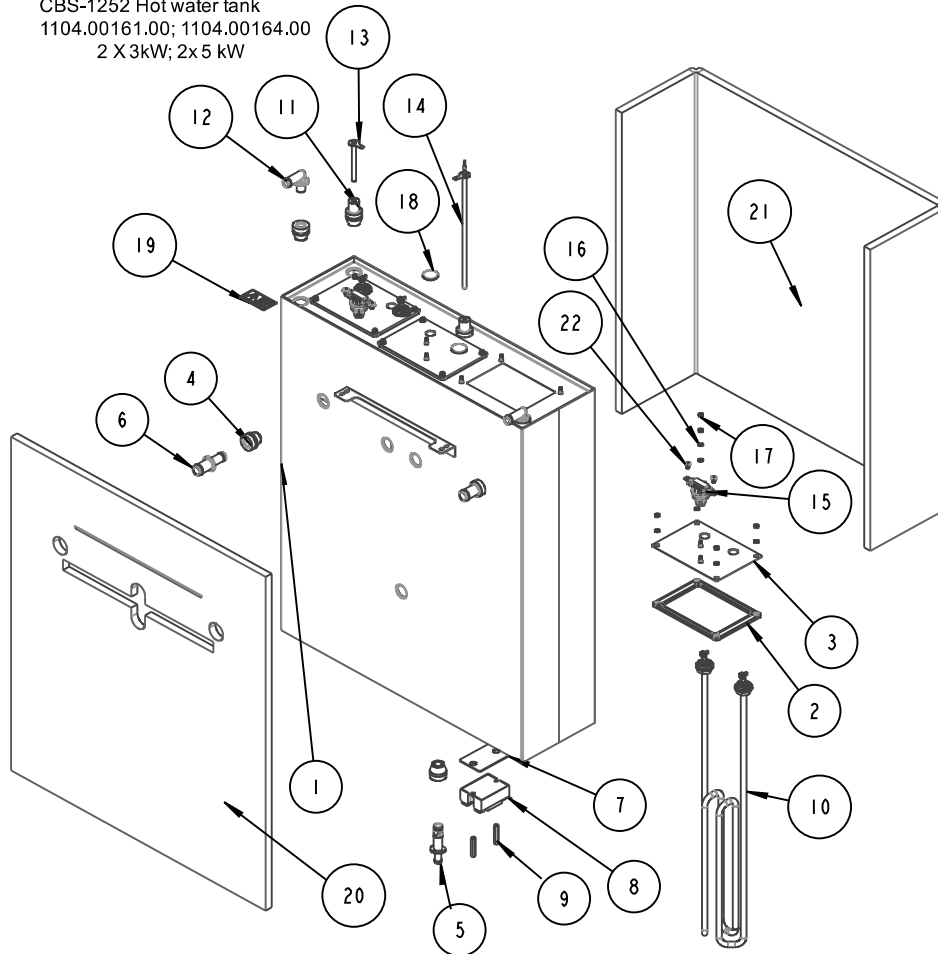

CBS-1252 Hot Water Tank Drawing 1104.00161.00 & 1104.00164.00

Ref#	Qty	Part number	Description
1	1	1114.00164.00	WELDMENT TANK, CBS-2252, LASER
2	3	1024.00115.00	TANK GASKET - NG HEATER PLATE, ONE ELEMENT
3	3	1114.00181.00	WELDMENT TANK HEATER BRACKET, NG-2232
4	5	1024.00050.00	GROMMET, SILICONE, 11.4mm ID
5	1	1023.00166.00	FITTING, COLD WATER INLET, GROMMET DESIGN
6	2	1023.00203.00	FITTING, STRAIGHT, GROMMET, .625"
7	2	1003.00140.00	ALUMINUM BRACKET FOR SSR
8	2	1052.00033.00	RELAY, SOLID STATE, 50A/480VAC, W/BUILD IN VARISTOR
9	4	1081.00042.00	STANDOFF, 1/4" HEX
10	2	1107.00005.00	ASSEMBLY, IMMERSION HEATER, 3000W, 240VAC
10	2	1107.00032.00	ASSEMBLY, IMMERSION HEATER, 5000W, 240VAC
11	2	1024.00053.00	LEVEL AND TEMP PROBE GROMMET
12	2	1023.00212.00	FITTING, ELBOW, GROMMET, .500"
13	1	1112.00019.00	PROBE WELDMENT, WATER LEVEL 2.600" LG
14	1	1102.00161.00	PROBE ASSEMBLY, TEMP. AND LLC, 8" LONG
15	2	1053.00052.00	THERMOSTAT, SINGLE SHOT, SCREW CONNECTIONS, 240V/25A
16	16	1083.00009.00	WASHER, #6 SCREW, INTL TOOTH LOCKWASHER
17	16	1084.00010.00	NUT, HEX, #6-32, UNDERSIZED, ZINC PLATED
18	2	1024.00054.00	GROMMET, SILICONE PLUG
19	1	1044.00004.00	LABEL, DANGER, HIGH VOLTAGE
20	1	1022.00070.00	INSULATION, TANK FRONT, CBS-2152
21	1	1022.00071.00	INSULATION, TANK BACK, CBS-2152
22	4	1082.00136.00	BRASS SCREW, #8-32 X 1/4", PHILLIPS PAN HEAD

CBS-1252 Hot water tank
 1104.00160.00; 1104.00162.00; 1104.00163.00
 3 X 3kW; 3 X 4 kW & 3 x5 kW

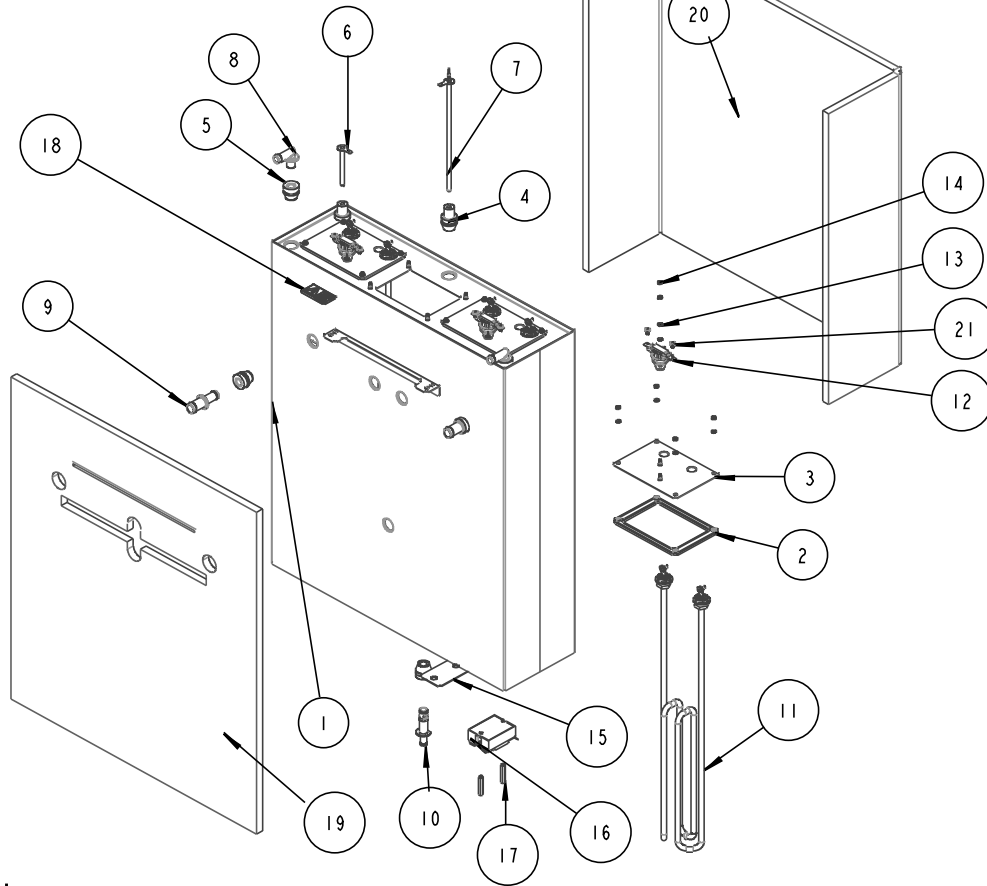

CBS-1252 and CBS-1253 Hot Water Tank Drawing 1104.00160.00; 1104.00162.00; 1104.00163.00

Ref#	Qty	Part number	Description
1	1	1114.00164.00	WELDMENT TANK, CBS-2252, LASER
2	3	1024.00115.00	TANK GASKET - NG HEATER PLATE, ONE ELEMENT
3	3	1114.00181.00	WELDMENT TANK HEATER BRACKET, NG-2232
4	2	1024.00053.00	LEVEL AND TEMP PROBE GROMMET
5	5	1024.00050.00	GROMMET, SILICONE, 11.4mm ID
6	1	1112.00019.00	PROBE WELDMENT, WATER LEVEL 2.600" LG
7	1	1102.00161.00	PROBE ASSEMBLY, TEMP. AND LLC, 8" LONG
8	2	1023.00212.00	FITTING, ELBOW, GROMMET, .500"
9	2	1023.00203.00	FITTING, STRAIGHT, GROMMET, .625"
10	1	1023.00166.00	FITTING, COLD WATER INLET, GROMMET DESIGN
11	1	1107.00005.00	ASSEMBLY, IMMERSION HEATER, 3000W, 240VAC
11	1	1107.00010.00	ASSEMBLY, IMMERSION HEATER, 4000W, 240VAC
11	1	1107.00032.00	ASSEMBLY, IMMERSION HEATER, 5000W, 240VAC
12	3	1053.00052.00	THERMOSTAT, SINGLE SHOT, SCREW CONNECTIONS, 240V/25A,
13	18	1083.00009.00	WASHER, #6 SCREW , INTL TOOTH LOCKWASHER
14	18	1084.00010.00	NUT, HEX, #6-32, UNDERSIZED, ZINC PLATED
15	3	1003.00140.00	ALUMINUM BRACKET FOR SSR
16	3	1052.00033.00	RELAY, SOLID STATE, 50A/480VAC, W/BUILD IN VARISTOR
17	6	1081.00042.00	STANDOFF, 1/4" HEX
18	1	1044.00004.00	LABEL, DANGER, HIGH VOLTAGE
19	1	1022.00070.00	INSULATION, TANK FRONT, CBS-2152
20	1	1022.00071.00	INSULATION, TANK BACK, CBS-2152
21	6	1082.00136.00	BRASS SCREW, #8-32 X 1/4", PHILLIPS PAN HEAD

Quick connect spray head assembly

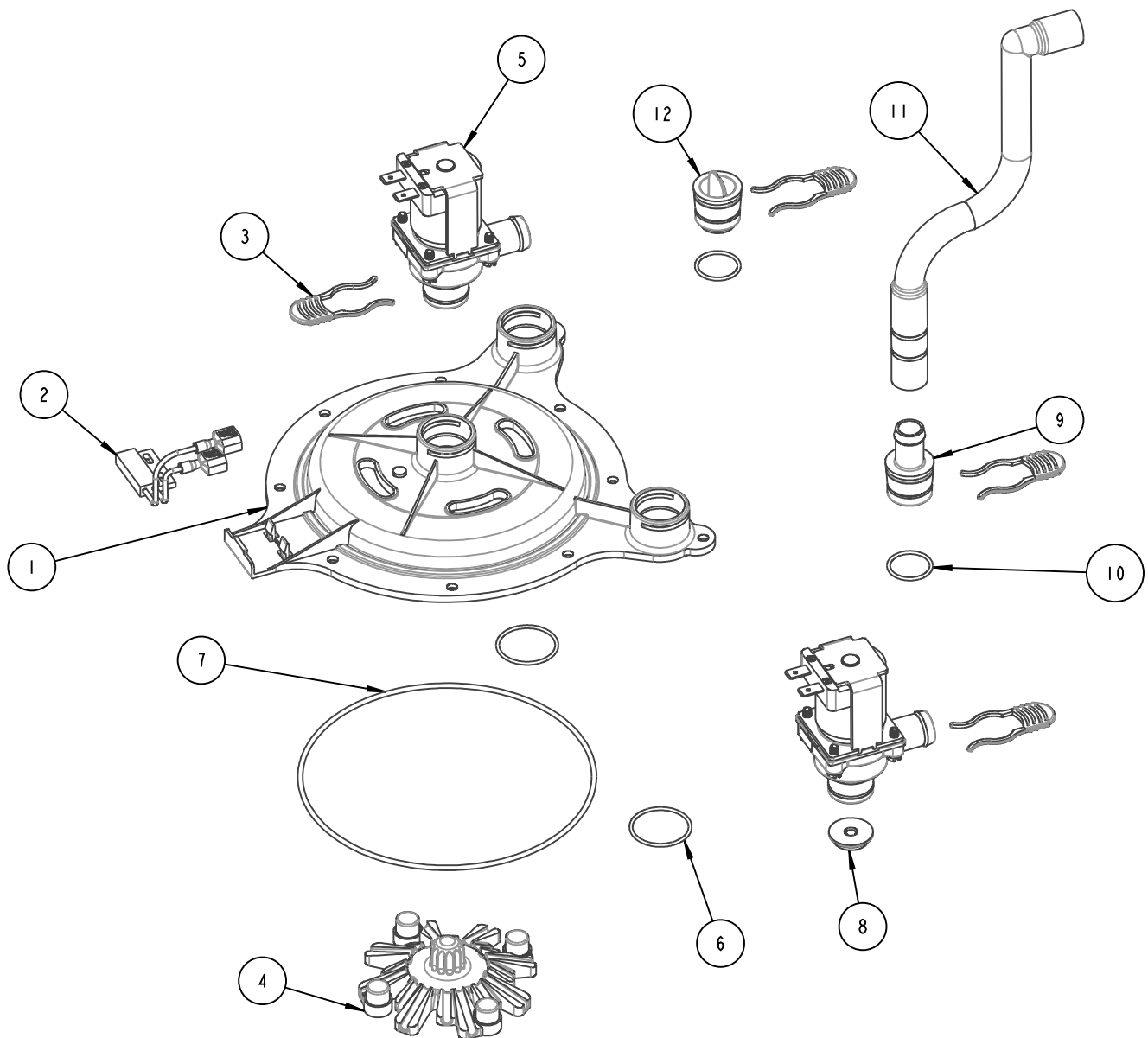

CBS-2151; CBS-1252 and CBS-1253 1102.00450.00 QUICK CONNECT SPRAYHEAD ASSEMBLY

Ref#	Qty	Part number	Description
1	1	1023.00341.00	BASE, QUICK CONNECT SPRAY HEAD
2	1	1102.00113.00	SWITCH, REED, ASSEMBLY
3	3	1023.00342.00	QUICK CONNECT CLIP
4	1	1102.00043.00	CASCADE SPRAY DOME, CBS-2050/60'S
5	2	1057.00076.00	VALVE ASSEMBLY, COMPLETE, NG, DELTROL (interchangeable with 1057.00078.00)
5	2	1057.00078.00	VALVE ASSEMBLY, COMPLETE, NG, RPE (interchangeable with 1057.00076.00)
6	2	1024.00107.00	O-RING, 1 3/16" OD X 1 1/16" ID X 1/16" TH, BYPASS SEAL
7	1	1024.00108.00	O-RING, 5 11/16"OD X 5 1/2" ID X 3/32" TH, BREW SEAL
8	1	1023.00369.00	ORIFICE INSERT, QUICK CONNECT, 3/16" HOLE
9	1	1023.00343.00	VENT INSERT, QUICK CONNECT
10	2	1024.00106.00	O-RING, 13/16"OD X 11/16"ID X 1/16" TH, FOR QUICK CONNECT
11	1	1024.00098.00	VENT TUBE, CBS- EXTRACTOR SERIES
12	1	1023.00344.00	PLUG INSERT, QUICK CONNECT

Wiring Diagrams

CBS-1251 PLUS
 Wiring diagram 1401.00196.10
 SKU: E1251US-1B230-PM110; heaters 2 X 3.0 kW
 SKU: E1251IN-1B230-PM110; heaters 2 X 3.0 kW

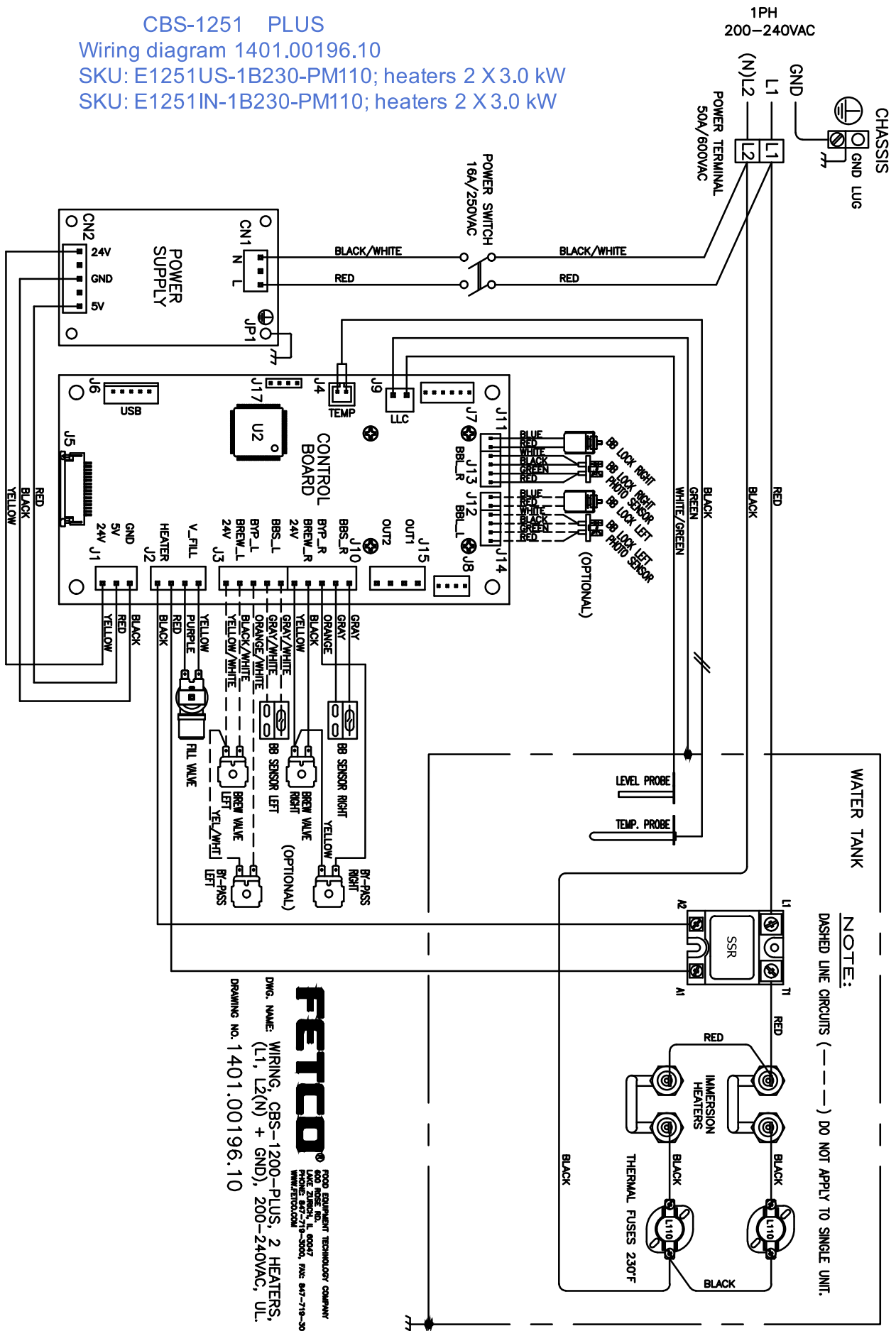

FETCO
 FOOD EQUIPMENT TECHNOLOGY COMPANY
 600 N. ZIMMER, L. 0047
 LAKE ZIMMER, CA 95024, PH: 947-710-3001
 WWW.FETCO.COM
 DWG. NAME: WIRING, CBS-1200-PLUS, 2 HEATERS,
 (L1, L2(N) + GND), 200-240VAC, UL.
 DRAWING NO. 1401.00196.10

CBS-1251 Plus
 Wiring Diagram 1401.00197.10
 SKU E1251IN-1B140-PM110; heaters 1 X 4.0 kW
 SKU E1251IN-1B150-PM110 ; heaters 1 X 5.0 kW

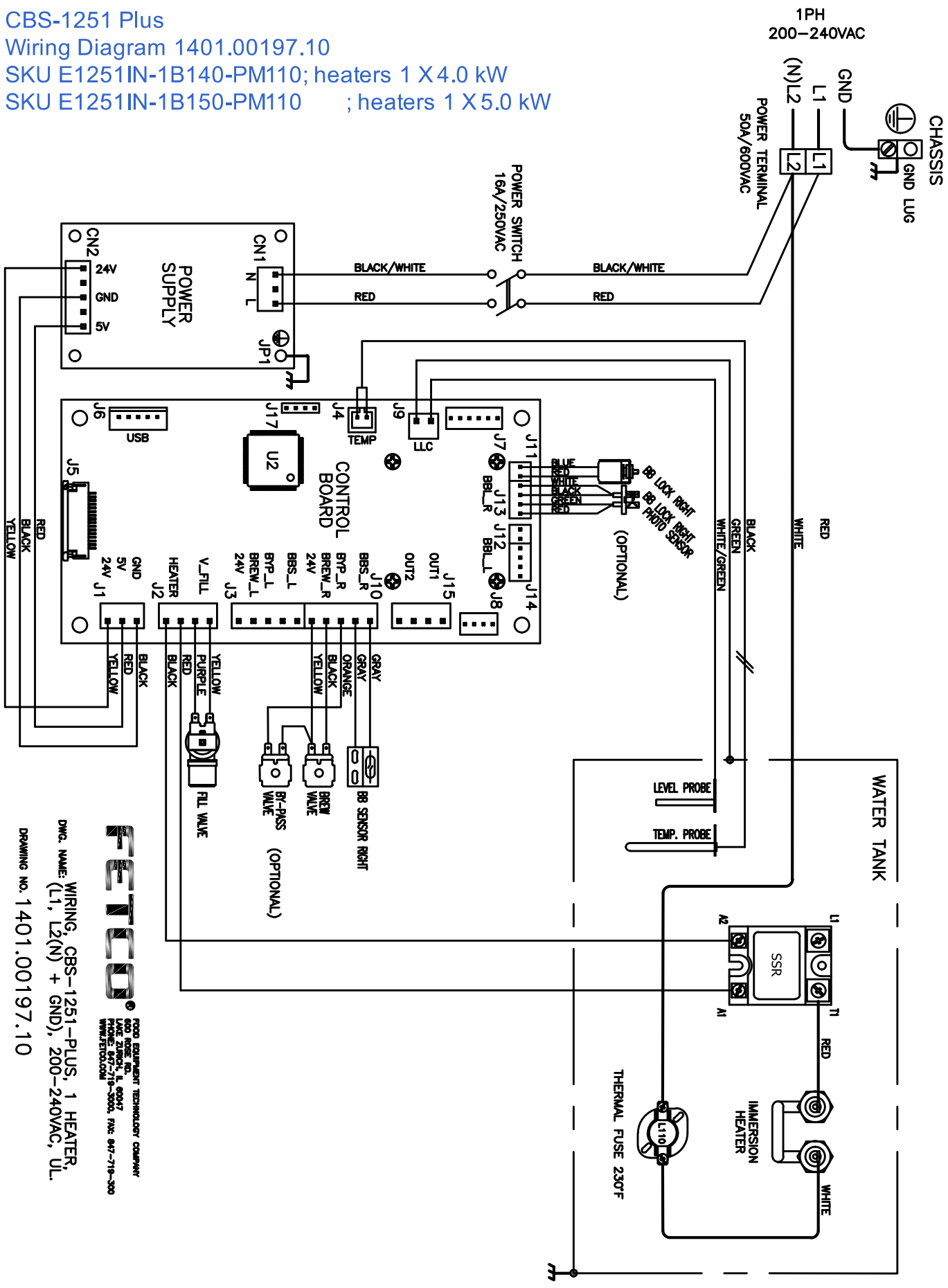

WIRING, CBS-1251-PLUS, 1 HEATER,
 (L1, L2(N) + GND), 200-240VAC, UL.

DWG. NAME: 1401.00197.10

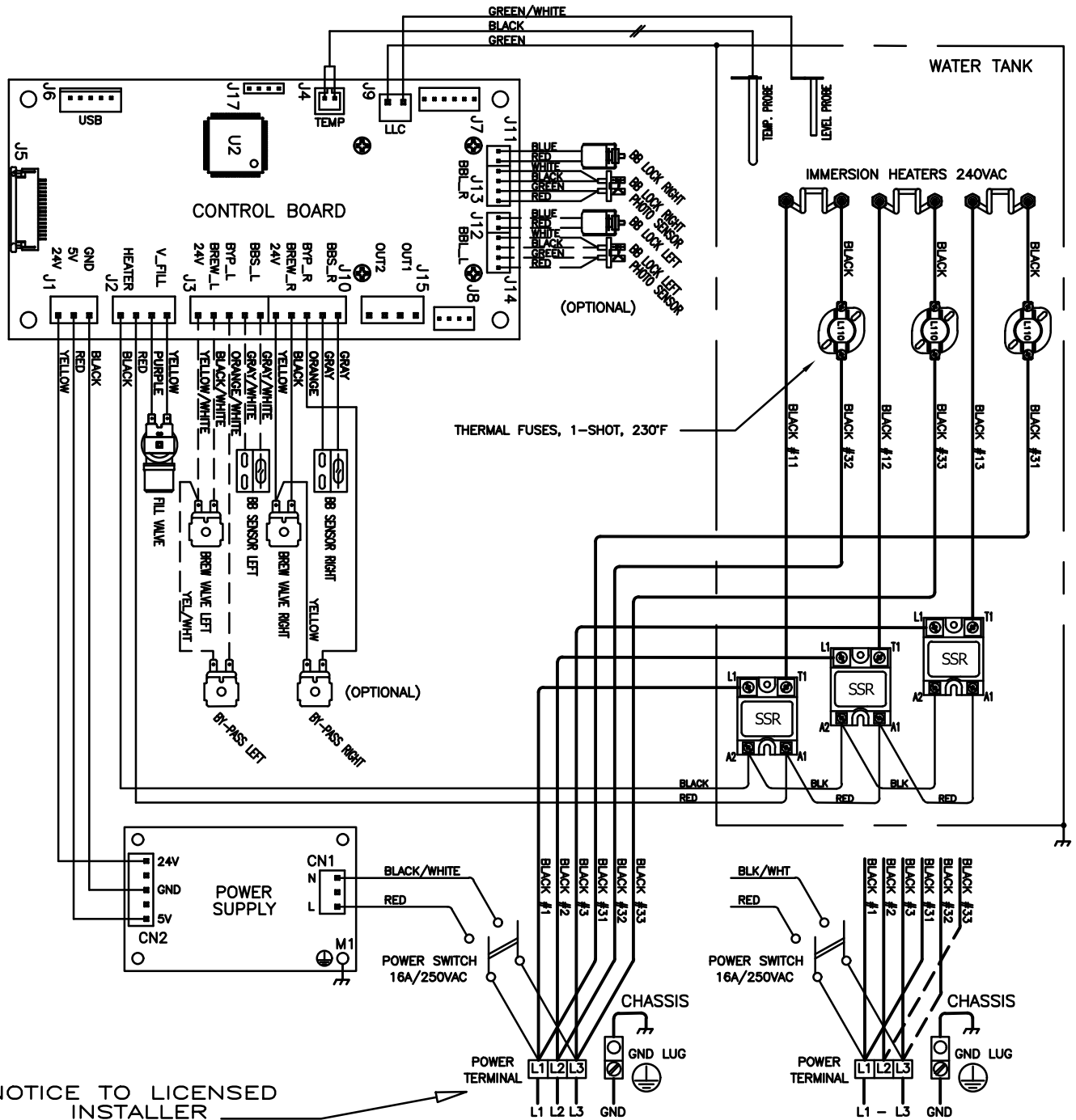

NOTICE TO LICENSED INSTALLER

THREE PHASE	SINGLE PHASE
POWER L1, L2, & L3	POWER L1 & L3 L2 - NOT CONNECTED
L1 - #1, #31	L1 - #1, #31
L2 - #2, #32	L2 - #2, #33
L3 - #3, #33	L3 - #3, #32
POWER TERMINAL CONNECTION	

FETCO FOOD EQUIPMENT TECHNOLOGY COMPANY
 600 RIDGE RD.
 LAKE ZURICH, IL 60047
 PHONE: 847-719-3000, FAX: 847-719-3007
 WWW.FETCO.COM

DRAWING NAME:
 WIRING DIAGRAM, CBS-1200-PLUS, 3 HEATERS, UNIVERSAL
 (L1, (L2), L3 + GND), 1 OR 3-PH, 200-240VAC, UL

DRAWING NO. 1401.00179.10

CBS-1252 V PlusWiring Diagram 1401.00197.10
 SKU E1253US-UB230-PM110 Heaters 2 X 3.0 kW single phase; 3 X 3.0 kW three phase
 SKU E1253US-UB250-PM110 Heaters 2 X 5.0 kW single phase; 3 X 5.0 kW three phase

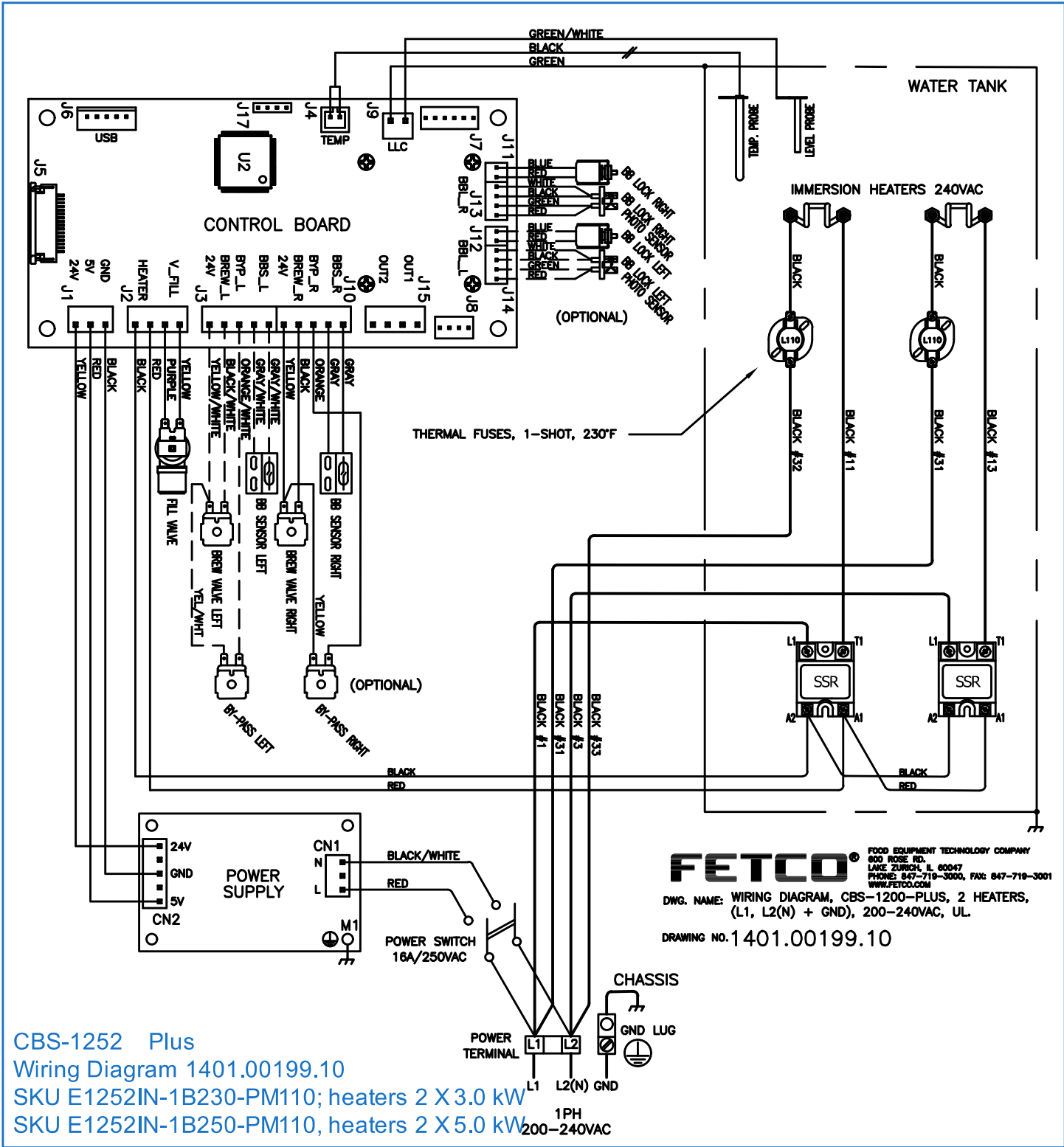

CBS-1252 Plus
 Wiring Diagram 1401.00199.10
 SKU E1252IN-1B230-PM110; heaters 2 X 3.0 kW
 SKU E1252IN-1B250-PM110; heaters 2 X 5.0 kW

NOTE:
 DASHED LINE CIRCUITS (---) DO NOT APPLY TO SINGLE UNIT.

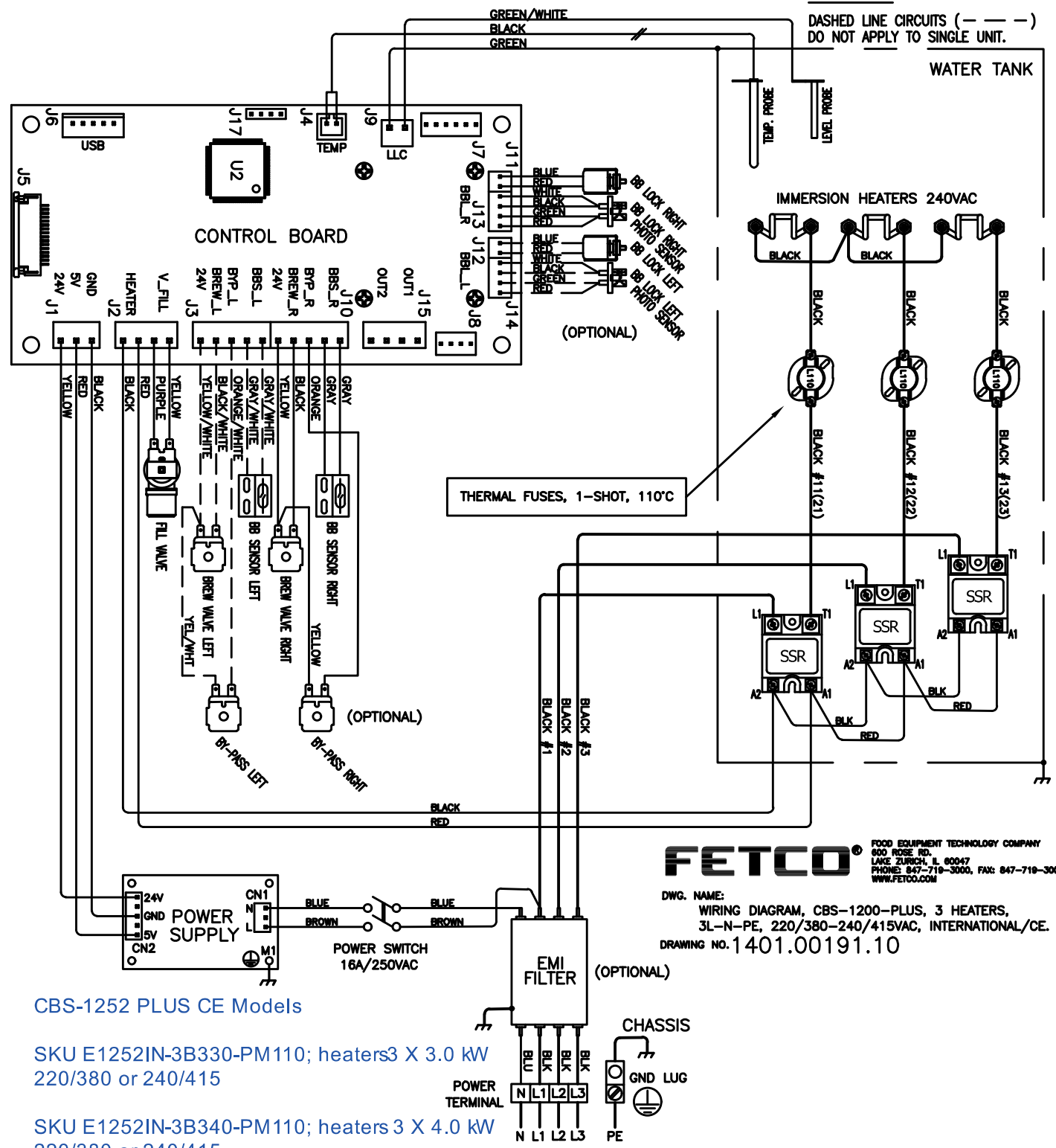

FETCO
 FOOD EQUIPMENT TECHNOLOGY COMPANY
 600 ROSE RD.
 LAKE ZURICH, IL 60047
 PHONE: 847-719-3000, FAX: 847-719-3001
 WWW.FETCO.COM

DWG. NAME:
 WIRING DIAGRAM, CBS-1200-PLUS, 3 HEATERS,
 3L-N-PE, 220/380-240/415VAC, INTERNATIONAL/CE.
 DRAWING NO. 1401.00191.10

CBS-1252 PLUS CE Models

SKU E1252IN-3B330-PM110; heaters 3 X 3.0 kW
 220/380 or 240/415

SKU E1252IN-3B340-PM110; heaters 3 X 4.0 kW
 220/380 or 240/415

SKU E1252IN-3B350-PM110; heaters 3 X 5.0 kW (230/400VAC - CE)
 220/380 or 240/415

